

PHILIPS

HD9916

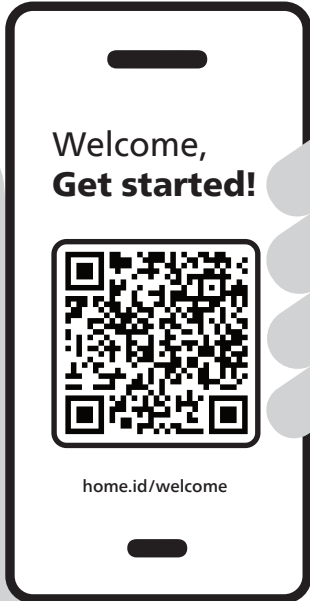



Registration
and Benefits





Digital manual

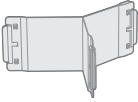

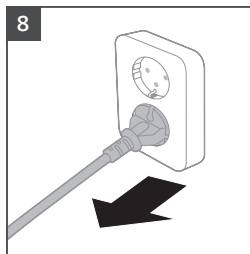
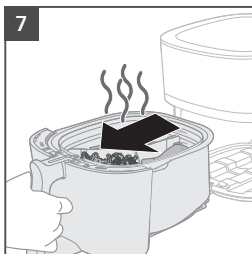
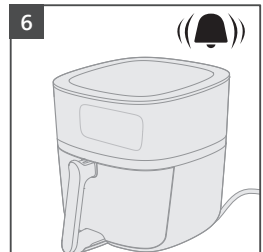
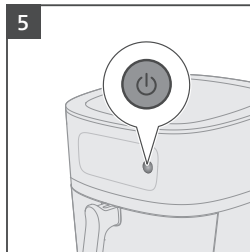
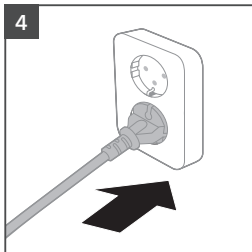
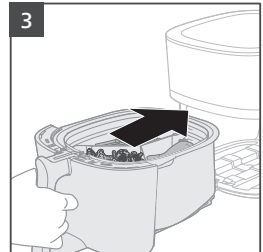
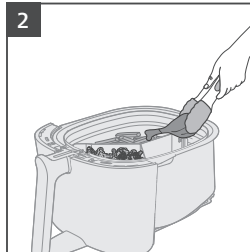
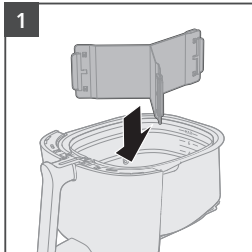
English	4
Български	6
Čeština	8
Dansk	10
Deutsch	12
Αγγλικά	14
Español	16
Eesti	18
Suomi	20
Français	22
Hrvatski	24
Magyar	26
Bahasa Indonesia	28
Italiano	30
한국어	32
Lietuvių	34
Latviešu	36
Македонски	38
Bahasa Melayu	40
Nederlands	42
Norsk	44
Polski	46
Português	48
Română	50
Slovenčina	52
Slovenščina	54
Shqip	56
Srpski	58
Svenska	60
ไทย	62
Türkçe	64
Українська	66
Tiếng Việt	68
简体中文	70
繁體中文	72
فارسی	75
العربية	77

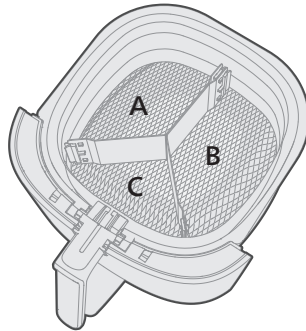
			
	✓	✓	✓





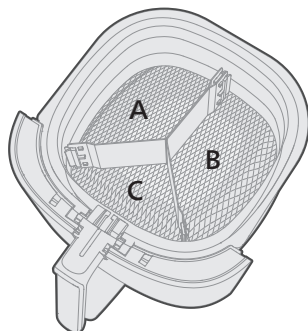

Dishes	Compartment	Ingredients		
Breakfast	Left (A)	5 eggs	8–9 min	160°C
	Right (B)	5 pieces of breads or 5 croissants		
	Low (C)	4 slices of toast		
English breakfast	Left (A)	4 small sausages + 4 pieces breakfast lard	10–11 min	180°C
	Right (B)	4 egg souffles in muffin cups		
	Low (C)	4 slices of toast bread		
Meal option 1: 1 chicken breast / small potatoes / vegetable mix	Left (A)	4 small biologic chicken breasts	22–25 min, 180°C Optional: use the temperature probe and set to 73°C to make the meal in one go without hassle.	
	Right (B)	900 g chopped vegetables cut in 1.5 cm mixed with 1 tablespoon oil		
	Low (C)	800 g small, peeled potatoes mixed with 1 tablespoon of oil		
Meal option 2: Pork tenderloin / baked potatoes / vegetable mix	Left (A)	2 pork tenderloin marinated and cut in half to 4 equal pieces	1. Bake potatoes with skin for 12 minutes at 180°C. 2. Add vegetables in the low compartment and tenderloin in the left compartment and fry together for 15 minutes at 180°C and stir vegetables once during cooking.	
	Right (B)	4 floury potatoes medium size		
	Low (C)	800 g vegetable mix cut in 1.5 cm and mixed with 1 tablespoon oil		

Dishes	Compartment	Ingredients		
Fish & Chips	Left (A)	4 pieces of fish with a cornflake crust	<ol style="list-style-type: none"> Place the fries in the basket and fry for 15 minutes at 180°C. Shake and slide the fries to the right side of the basket with the pan divider. Add on the left side 4 pieces of fish and fry for 12 minutes at 180°C and turn the fish halfway through the cooking time. 	
	Right (B)	1.2 kg of frozen fries		
Meal option 3: Roast beef with vegetables and potatoes	Left (A)	Big roast beef from 900 g	<ol style="list-style-type: none"> Add roast beef in the left compartment and add temperature probe and program on 50/55/60°C. Halfway through the cooking time, add vegetables in the low compartment and potatoes in the right compartment until the temperature is reached. 	
	Right (B)	800 g potato wedges		
	Low (C)	700 g chopped vegetables		
Fries & Snacks	Left (A)	4 chicken nuggets.	<ol style="list-style-type: none"> Fry everything together at 180°C until food gets crispy. 	
	Right (B)	800 g potato cubes		
	Low (C)	Vegetarian snacks mushrooms with crunchy crust		
Vegetarian Asian snack time	Left (A)	400 g marinated crab bites 2cm	<ol style="list-style-type: none"> Add crab bites in the left compartment and spring rolls and tofu skewers in the right compartment, and fry for 12 minutes at 180°C. Add crackers in the low compartment and fry together for 4 minutes at 180°C until food gets crispy. 	
	Right (B)	500 g vegetarian spring rolls + 4 vegetarian tofu skewers		
	Low (C)	100 g udang crackers		



Съдове	Отделение	Съставки		
Закуска	Ляво (А)	5 яйца	8 – 9 мин	160°C
	Дясно (В)	5 парчета хляб или 5 кроасана		
	Ниски (С)	4 филийки хляб		
Английска закуска	Ляво (А)	4 малки наденички + 4 парчета свинска мас за закуска	10 – 11 мин	180°C
	Дясно (В)	4 яйчени суфлета в чашки за мъфини		
	Ниски (С)	4 филийки препечен хляб		
Вариант за ястие 1: 1 брой пилешки гърди/малки картофи/ зеленчуков микс	Ляво (А)	4 малки био пилешки гърди	22 – 25 минути, 180°C	По желание: използвайте кухненски термометър и задайте температурата на 73°C, за да пригответе ястието наведнъж и без проблеми.
	Дясно (В)	900 г зеленчуци, нарязани на 1,5 см, смесени с 1 с.л. олио		
	Ниски (С)	800 г малки, обелени картофи, смесени с 1 с.л. олио		
Вариант за ястие 2: свинско филе/печени картофи/ зеленчуков микс	Ляво (А)	2 мариновани свински филета, разрязани наполовина на 4 равни парчета	1. Печете картофите с кожата за 12 минути на 180°C. 2. Добавете зеленчуците отдолу и филето отляво и пържете заедно за 15 минути на 180°C, като разбърквате зеленчуците веднъж по време на готвенето.	
	Дясно (В)	4 цветни картофа със среден размер		
	Ниски (С)	800 г микс от зеленчуци, нарязани на 1,5 см и смесени с 1 с.л. олио		

Съдове	Отделение	Съставки		
Риба и пържени картофи	Ляво (А)	4 парчета риба с коричка от корнфлейкс		
	Дясно (В)	1,2 kg замразени картофи за пържене		
Вариант за ястие 3: печено говеждо със зеленчуци и картофи	Ляво (А)	Голямо говеждо месо за печене от 900 g		
	Дясно (В)	800 g картофени с кожичка		
	Ниски (С)	700 g нарязани зеленчуци		
Пържени картофи и аламинуту	Ляво (А)	4 пилешки хапки.		
	Дясно (В)	800 g картофи на кубчета		
	Ниски (С)	Вегетариански аламинуту от гъби с хрупкава коричка		
Вегетариански азиатски аламинуту	Ляво (А)	400 g мариновани хапки от раци с размер 2 см		
	Дясно (В)	500 g вегетариански пролетни рулца + 4 вегетариански шишчета от тофу		
	Ниски (С)	100 g крекери udang		



1. Поставете картофките в кошницата и ги пържете 15 минути на 180°C.
2. Разклатете и преместете пържените картофи към дясната страна на кошницата с помощта на разделителя. Добавете 4 парчета риба отляво и пържете 12 минути на 180°C, като обърнете рибата по средата на времето за готвене.

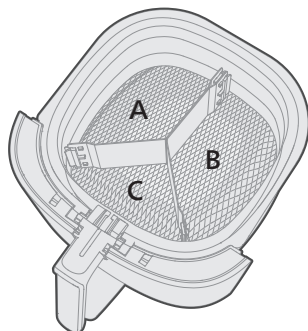

1. Добавете говеждото месо за печене отляво, добавете кухненския термометър и програмирайте на 50/55/60°C.
2. По средата на времето за готвене добавете зеленчуци отдолу и картофи отдясно, докато се достигне температурата.

1. Запържете всичко заедно на 180°C, докато храната стане хрупкава.



1. Добавете хапки от раци отляво и пролетни рулца и шишчета от тофу отдясно и пържете за 12 минути на 180°C.
2. Добавете крекери отдолу и пържете заедно за 4 минути на 180°C, докато храната стане хрупкава.



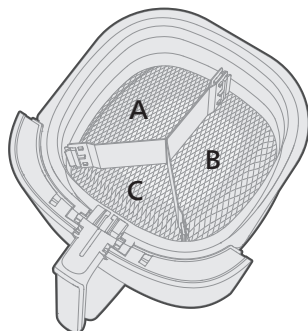

Pokrm	Prostor	Předvolba		
Snídaně	Levý (A)	5 vajec	8–9 min	160°C
	Pravý (B)	5 kusů chleba nebo 5 rohlíčů		
	Spodní (C)	4 plátky toastu		
Anglická snídaně	Levý (A)	4 malé párky + 4 kusy sádla	10–11 min	180°C
	Pravý (B)	4 vaječné suflé v muffinových košíčcích		
	Spodní (C)	4 plátky toastového chleba		
Možnost jídla 1: 1 kuřecí prso / malé brambory / zeleninová směs	Levý (A)	4 malá bio kuřecí prsa	22–25 min, 180°C Volitelně: použijte teplotní sondu a nastavte teplotu na 73°C, abyste jídlo připravili najednou a bez potíží.	
	Pravý (B)	900 g zeleniny nakrájené na 1,5 cm a smíchané s 1 polévkovou lžící oleje		
	Spodní (C)	800 g malých oloupaných brambor smíchaných s 1 polévkovou lžící oleje		
Možnost jídla 2: vepřová panenka / pečené brambory / zeleninová směs	Levý (A)	2 vepřové panenky marinované a rozkrojené na polovinu na 4 stejné kusy	1. Brambory se slupkou pečte 12 minut při 180°C. 2. Přidejte zeleninu do spodního prostoru a panenku do levého prostoru a smažte společně 15 minut při 180°C; během smažení zeleninu jednou promíchejte.	
	Pravý (B)	4 středně velké moučnaté brambory		
	Spodní (C)	800 g zeleninové směsi nakrájené na 1,5 cm a smíchané s 1 polévkovou lžící oleje		
Ryba s hranolky	Levý (A)	4 kousky ryby s krustou z kukuřičných lupínků	1. Hranolky vložte do košíku a smažte 15 minut při 180°C. 2. Hranolky protřepejte a přesuňte na pravou stranu košíku pomocí rozdělovače pánve. Na levou stranu přidejte 4 kusy ryby a smažte 12 minut při 180°C; v polovině doby smažení rybu otočte.	
	Pravý (B)	1,2 kg zmrazených hranolků		

Pokrm	Prostor	Předvolba		
Možnost jídla 3: hovězí pečeně se zeleninou a brambory	Levý (A)	Velká hovězí pečeně od 900 g	<ol style="list-style-type: none"> Vložte hovězí roštěnou do levého prostoru a přidejte teplotní sondu a naprogramujte na 50/55/60°C. V polovině doby přípravy přidejte zeleninu do spodního prostoru a brambory do pravého prostoru, dokud není dosaženo teploty. 	
	Pravý (B)	800 g bramborových klínků		
	Spodní (C)	700 g nakrájené zeleniny		
Hranolky a pochutiny	Levý (A)	4 kuřecí nugetky.	<ol style="list-style-type: none"> Smažte vše společně při 180°C, dokud jídlo nebude křupavé. 	
	Pravý (B)	800 g bramborových kostek		
	Spodní (C)	Vegetariánské občerstvení – houby s křupavou kůrkou		
Vegetariánská asijská svačinka	Levý (A)	400 g marinovaných krabích kousků o velikosti 2 cm	<ol style="list-style-type: none"> Přidejte krabí kousky do levého prostoru a jarní závitky a tofu špízy do pravého prostoru a smažte 12 minut při 180°C. Přidejte krekrů do spodního prostoru a smažte společně 4 minuty při 180°C, dokud jídlo nebude křupavé. 	
	Pravý (B)	500 g vegetariánských jarních závitků + 4 vegetariánské tofu špízy		
	Spodní (C)	100 g krekrů udang		





Retter	Rum	Ingredienser		
Morgenmad	Venstre (A)	5 æg	8-9 min	160°C
	Højre (B)	5 skiver brød eller 5 croissanter		
	Lav (C)	4 skiver toast		
Engelsk morgenmad	Venstre (A)	4 små pølser + 4 skiver spæk	10-11 min	180°C
	Højre (B)	4 æggesouffléer i muffinforme		
	Lav (C)	4 skiver toastbrød		
Måltidsmulighed 1: 1 kyllingebryst/ små kartofler/ grøntsagsblanding	Venstre (A)	4 små økologiske kyllingebruster	22–25 min, 180°C	Valgfrit: Brug madtermometeret og indstil til 73°C grader for at tilberede måltidet på én gang.
	Højre (B)	900 g hakkede grøntsager skåret i 1,5 cm blandet med 1 spsk. olie		
	Lav (C)	800 g små, skrællede kartofler blandet med 1 spsk. olie		
Måltidsmulighed 2: Svinemørbrad/ bagte kartofler/ grøntsagsblanding	Venstre (A)	2 stk. svinemørbrad marineret og skåret i halve til 4 lige store stykker	1. Bag kartoflerne med skind i 12 minutter ved 180°C. 2. Tilsæt grøntsager i nederste rum og mørbrad i venstre rum, og tilbered sammen i 15 minutter ved 180°C, og rør i grøntsagerne én gang under tilberedningen.	
	Højre (B)	4 megede kartofler mellem størrelse		
	Lav (C)	800 g grøntsagsblanding skåret i 1,5 cm og blandet med 1 spsk. olie		
Fish & Chips	Venstre (A)	4 stk. fisk med panering af cornflakes	1. Læg pommes friter i kurven, og tilbered i 15 minutter ved 180°C. 2. Ryst og skub pommes friter til højre side af kurven med kurveopdeleren. Tilsæt side 4 stk. fisk i venstre side, og tilbered i 12 minutter ved 180°C, og vend fisken halvvejs gennem tilberedningen.	
	Højre (B)	1,2 kg frosne pommes friter		

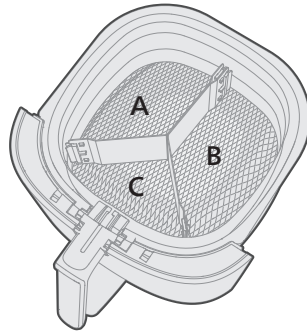

Retter	Rum	Ingredienser		
Måltidsmulighed 3: Oksesteg med grøntsager og kartofler	Venstre (A)	Stor oksesteg fra 900 g	<ol style="list-style-type: none"> Læg oksestegen i venstre side, og isæt madtermometeret, og indstil programmet på 50/55/60°C. Halvvejs gennem tilberedningstiden tilsættes grøntsager i nederste rum og kartoflerne i højre rum, indtil temperaturen er nået. 	
	Højre (B)	800 g kartoffelbåde		
	Lav (C)	700 g hakkede grøntsager		
Pommes fritter og snacks	Venstre (A)	4 kyllingenuggets.	<ol style="list-style-type: none"> Tilbered det hele sammen ved 180°C., indtil maden bliver sprød. 	
	Højre (B)	800 g kartoffeltern		
	Lav (C)	Vegetariske snacks – svampe med sprød skorpe		
Vegetarisk asiatisk snack	Venstre (A)	400 g marinerede krabbestykker 2 cm	<ol style="list-style-type: none"> Tilsæt krabbestykker i venstre side og forårsruller og tofuspyd i højre side, og tilbered i 12 minutter ved 180°C. Tilsæt kiks i bunden og tilbered sammen i 4 minutter ved 180°C, indtil maden bliver sprød. 	
	Højre (B)	500 g vegetariske forårsruller + 4 vegetariske tofuspyd		
	Lav (C)	100 g udang-kiks		



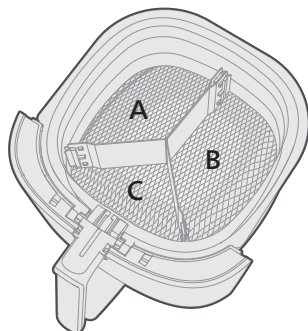

Gerichte	Fach	Inhaltsstoffe		
Frühstück	Links (A)	5 Eier	8–9 Min.	160°C
	Rechts (B)	5 Brötchen oder 5 Croissants		
	Niedrig (C)	4 Scheiben Toast		
Englisches Frühstück	Links (A)	4 kleine Würstchen + 4 Stücke Schmalz	10–11 Min.	180°C
	Rechts (B)	4 Eieraufläufe in Muffinförmchen		
	Niedrig (C)	4 Scheiben Toastbrot		
Mahlzeit Option 1: 1 Hähnchenbrustfilet/ kleine Kartoffeln/ Gemüsemix	Links (A)	4 Bio-Hähnchenbrustfilets	22–25 Min, 180°C Optional: Verwenden Sie die Temperatursonde und stellen Sie sie auf 73°C ein, um Ihre Mahlzeit mühelos in einem Durchgang zuzubereiten.	
	Rechts (B)	900 g zerkleinertes Gemüse in 1,5 cm Stücke mit einem Esslöffel Öl vermengen		
	Niedrig (C)	800 g kleine, geschälten Kartoffeln mit einem Esslöffel Öl vermengen		
Mahlzeit Option 2: Schweinefilet/ Backkartoffeln/ gemischtes Gemüse	Links (A)	2 marinierte Schweinefilets, halbiert in 4 gleichmäßige Stücke	1. Backkartoffeln, ungeschält, für 12 Minuten bei 180°C. 2. Fügen Sie unten Gemüse hinzu und links das Schweinefilet, gemeinsam für 15 Minuten bei 180°C frittieren. Gemüse einmal während der Zubereitung umrühren.	
	Rechts (B)	4 mehlig Kartoffeln, mittelgroß		
	Niedrig (C)	800 g gemischtes Gemüse in 1,5 cm geschnitten mit einem Esslöffel Öl vermengen		



Gerichte	Fach	Inhaltsstoffe		
Fish and Chips	Links (A)	4 Stücke Fisch mit Cornflakes-Panade	<ol style="list-style-type: none"> Geben Sie die Pommes frites in den Korb und frittieren Sie sie für 15 Minuten bei 180 C. Schütteln und schieben Sie die Pommes frites auf die rechte Seite des Korbes mit dem Korbtreuner. Geben Sie die 4 Fischstücke auf die linke Seite und frittieren Sie sie 12 Minuten bei 180°C und wenden Sie den Fisch nach der Hälfte der Garzeit. 	
	Rechts (B)	1,2 kg gefrorene Pommes frites		
Mahlzeit Option 3: Roastbeef mit Gemüse und Kartoffeln	Links (A)	Großes Roastbeef ab 900 g	<ol style="list-style-type: none"> Geben Sie das Roastbeef auf die linke Seite und geben Sie die Temperatursonde dazu und programmieren Sie sie auf 50/55/60°C. Geben Sie das Gemüse nach der Hälfte der Garzeit in den unteren Bereich und die Kartoffeln rechts, bis die Temperatur erreicht wurde. 	
	Rechts (B)	800 g Kartoffel-Wedges		
	Niedrig (C)	700 g zerkleinertes Gemüse		
Pommes frites und Snacks	Links (A)	4 Chicken Nuggets	<ol style="list-style-type: none"> Frittieren Sie alles bei 180°C, bis das Essen knusprig ist. 	
	Rechts (B)	800 g Kartoffeln, gewürfelt		
	Niedrig (C)	Vegetarischer Snack aus Pilzen mit knuspriger Panade		
Asiatische, vegetarische Snackzeit	Links (A)	400 g marinierte Krabben-Häppchen, 2 cm	<ol style="list-style-type: none"> Fügen Sie die Krabben-Häppchen auf die linke Seite und die Frühlingsrollen und Tofu-Spieße auf die rechte Seite und frittieren Sie alles für 12 Minuten bei 180°C. Geben Sie die Cracker unten hinein und frittieren Sie alles für 4 Minuten bei 180 C, bis das Essen knusprig ist. 	
	Rechts (B)	500 g vegetarische Frühlingsrollen + 4 vegetarische Tofu-Spieße		
	Niedrig (C)	100 g Krabben-Chips		



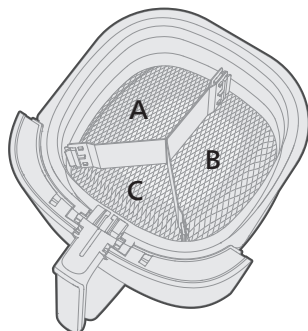

Πιάτα	Χώρος αποθήκευσης	Υλικά		
Πρωινό	Αριστερό (A)	5 αυγά	8–9 λεπτά	160°C
	Δεξί (B)	5 φέτες ψωμιού ή 5 κρουασάν		
	Χαμηλά (C)	4 φέτες τوست		
Αγγλικό πρωινό	Αριστερό (A)	4 μικρά λουκάνικα + 4 κομμάτια λαρδί	10–11 λεπτά	180°C
	Δεξί (B)	4 σουφλέ αυγών σε φορμάκια για μάφιν		
	Χαμηλά (C)	4 φέτες ψωμί του τوست		
Επιλογή γεύματος 1: 1 στήθος κοτόπουλου / μικρές πατάτες / μείγμα λαχανικών	Αριστερό (A)	4 μικρά βιολογικά στήθη κοτόπουλου	22–25 λεπτά, 180°C	Προαιρετικά: Χρησιμοποιήστε το θερμομέτρο και ρυθμίστε στους 73°C για να μαγειρέψετε το γέυμα σε μία δόση χωρίς ταλαιπωρία.
	Δεξί (B)	900 γρ. ψιλοκομμένα λαχανικά κομμένα σε 1,5 εκ. αναμεμειγμένα με 1 κ.σ. λάδι		
	Χαμηλά (C)	800 γρ. μικρές, αποφλοιωμένες πατάτες αναμεμειγμένες με 1 κ.σ. λάδι		
Επιλογή γεύματος 2: Χοιρινό ψαρονέφρι / πατάτες φούρνου / μείγμα λαχανικών	Αριστερό (A)	2 κομμάτια χοιρινό ψαρονέφρι μαριναρισμένο και κομμένο στη μέση σε 4 ίσα κομμάτια	1. Ψήστε τις πατάτες με τη φλούδα για 12 λεπτά στους 180°C	2. Προσθέστε τα λαχανικά στο κάτω τμήμα και το ψαρονέφρι στο αριστερό τμήμα και τηγανίστε τα μαζί για 15 λεπτά στους 180°C. Ανακατέψτε τα λαχανικά μία φορά κατά τη διάρκεια του μαγειρέματος.
	Δεξί (B)	4 αλευρώδεις πατάτες μεσαίου μεγέθους		
	Χαμηλά (C)	800 γρ. μείγμα λαχανικών κομμένα σε 1,5 εκ. και αναμεμειγμένα με 1 κ.σ. λάδι		



Πιάτα	Χώρος αποθήκευσης	Υλικά		
Τηγανητό ψάρι και πατάτες (Fish and Chips)	Αριστερό (A)	4 κομμάτια ψαριού με κρούστα από νιφάδες καλαμποκιού		<ol style="list-style-type: none"> 1. Τοποθετήστε τις πατάτες στο καλάθι και τηγανίστε τις για 15 λεπτά στους 180°C. 2. Ανακινήστε και σύρετε τις πατάτες στη δεξιά πλευρά του καλάθιου με το διαχωριστικό για τηγάνι. Προσθέστε στην αριστερή πλευρά 4 κομμάτια ψαριού και τηγανίστε για 12 λεπτά στους 180°C. Γυρίστε τα ψάρια στα μισά του χρόνου μαγειρέματος.
	Δεξί (B)	1,2 κ. κατεψυγμένες πατάτες		
Επιλογή γεύματος 3: Ροσμπίφ με λαχανικά και πατάτες	Αριστερό (A)	Μεγάλο ροσμπίφ από 900 γρ.		<ol style="list-style-type: none"> 1. Προσθέστε το ροσμπίφ στο αριστερό τμήμα και το θερμομέτρο και προγραμματίστε στους 50/55/60°C. 2. Στα μισά του χρόνου μαγειρέματος, προσθέστε τα λαχανικά στο κάτω τμήμα και τις πατάτες στο δεξί τμήμα μέχρι να επιτευχθεί η θερμοκρασία.
	Δεξί (B)	800 γρ. πατάτες κυδωνάτες		
	Χαμηλά (C)	700 γρ. ψιλοκομμένα λαχανικά		
Τηγανητά και σνακ	Αριστερό (A)	4 κοτομπουκιές.		<ol style="list-style-type: none"> 1. Τηγανίζουμε τα πάντα μαζί στους 180°C μέχρι το φαγητό να γίνει τραγανό.
	Δεξί (B)	800 γρ. πατάτες σε κύβους		
	Χαμηλά (C)	Χορτοφαγικά σνακ: μανιτάρια με τραγανή κρούστα		
Ώρα για χορτοφαγικά ασιατικά σνακ	Αριστερό (A)	400 γρ. μαριναρισμένες μπουκιές καβουριού 2 εκ.		<ol style="list-style-type: none"> 1. Προσθέστε τις μπουκιές καβουριού στο αριστερό τμήμα και τα σπρινγκ ρολ και τα σουβλάκια τόφου στο δεξί τμήμα και τηγανίστε τα για 12 λεπτά στους 180°C. 2. Προσθέστε τα κράκερ στο κάτω τμήμα και τηγανίστε μαζί για 4 λεπτά στους 180°C μέχρι το φαγητό να γίνει τραγανό.
	Δεξί (B)	500 γρ. χορτοφαγικά σπρινγκ ρολ + 4 χορτοφαγικά σουβλάκια τόφου		
	Χαμηλά (C)	100 γρ. κράκερ γαρίδας		



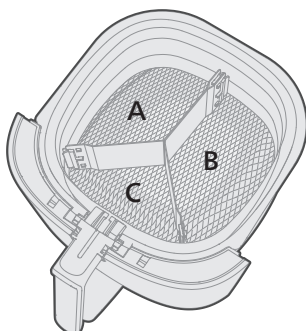

Platos	Compartimento	Ingredientes		
Desayuno	Izquierdo (A)	5 huevos	8-9 min	160°C
	Derecho (B)	5 rebanadas de pan o 5 croissants		
	Inferior (C)	4 tostadas		
Desayuno inglés	Izquierdo (A)	4 salchichas pequeñas + 4 piezas de manteca de desayuno	10-11 min	180°C
	Derecho (B)	4 suflés de huevo en moldes para magdalenas		
	Inferior (C)	4 tostadas		
Opción de comida 1: 1 pechuga de pollo / patatas pequeñas / verduras variadas	Izquierdo (A)	4 pechugas de pollo orgánico pequeñas	22-25 min, 180°C	Opcional: utilice la sonda de temperatura para ajustarla a 73°C con el fin de preparar la comida de una sola vez y sin complicaciones.
	Derecho (B)	900 g de verduras picadas en trozos de 1,5 cm y mezcladas con 1 cucharada de aceite		
	Inferior (C)	800 g de patatas pequeñas peladas y mezcladas con 1 cucharada de aceite		
Opción de comida 2: solomillo de cerdo / patatas al horno / verduras variadas	Izquierdo (A)	2 solomillos de cerdo marinados y cortados por la mitad en 4 trozos iguales	1. Hornee las patatas sin pelar durante 12 minutos a 180°C. 2. Añada las verduras en el compartimento inferior y el solomillo en el izquierdo, fríalos a la vez durante 15 minutos a 180°C y remueva las verduras una vez durante la cocción.	
	Derecho (B)	4 patatas harinosas de tamaño medio		
	Inferior (C)	800 g de verduras variadas cortadas en trozos de 1,5 cm y mezcladas con 1 cucharada de aceite		

Platos	Compartimento	Ingredientes		
Fish and chips	Izquierdo (A)	4 trozos de pescado rebozados con copos de maíz	<ol style="list-style-type: none"> 1. Coloque las patatas fritas en la cesta y fríalas durante 15 minutos a 180°C. 2. Agite las patatas fritas y apártelas al lado derecho de la cesta con el separador. Añade 4 trozos de pescado en el lado izquierdo y fríalos durante 12 minutos a 180°C, dándoles la vuelta a mitad de cocción. 	
	Derecho (B)	1,2 kg de patatas fritas congeladas		
Opción de comida 3: ternera asada con verduras y patatas	Izquierdo (A)	Filete grande de ternera de 900 g	<ol style="list-style-type: none"> 1. Añada el filete de ternera a la izquierda, añada una sonda y programe la temperatura a 50/55/60°C. 2. A mitad de cocción, añada las verduras en el compartimento inferior y las patatas en el derecho hasta alcanzar la temperatura adecuada. 	
	Derecho (B)	800 g de gajos de patata		
	Inferior (C)	700 g de verduras picadas		
Patatas fritas y aperitivos	Izquierdo (A)	4 nuggets de pollo.	<ol style="list-style-type: none"> 1. Fría todo a la vez a 180°C hasta que los alimentos adquieran una textura crujiente. 	
	Derecho (B)	800 g de patata en dados		
	Inferior (C)	Aperitivos vegetarianos de champiñón con rebozado crujiente		
Aperitivo vegetariano asiático	Izquierdo (A)	400 g de bocaditos de cangrejo marinados de 2 cm	<ol style="list-style-type: none"> 1. Añada los bocaditos de cangrejo a la izquierda y los rollitos de primavera y las brochetas de tofu a la derecha, y fría durante 12 minutos a 180°C. 2. Añada las galletas saladas en el compartimento inferior y fríalo todo junto durante 4 minutos a 180°C hasta que los alimentos adquieran una textura crujiente. 	
	Derecho (B)	500 g de rollitos de primavera vegetarianos + 4 brochetas vegetarianas de tofu		
	Inferior (C)	100 g de pan de gambas		





Road	Hoiustus	Koostisained		
Homnikusöök	Vasak (A)	5 muna	8–9 min	160°C
	Parem (B)	5 tükki leiba või 5 sarvesaia		
	Madal (C)	4 viilu röstsaia		
Inglise hommikusöök	Vasak (A)	4 väikest vorsti + 4 tükki hommikusöögisinki	10–11 min	180°C
	Parem (B)	4 munasufleed muffinivormides		
	Madal (C)	4 viilu röstleiba		
Einevariant 1: 1 kanarind / väikesed kartulid / köögiviljasegu	Vasak (A)	4 väikest orgaanilist kanarinda	22–25 min, 180°C	Valikuline: kasutage temperatuuriandurit ja seadke see 73°C peale, et valmistada eine ühe korraga ilma probleemideta.
	Parem (B)	900 g köögivilju, mis on hakitud 1,5 cm suurustekst tükkideks ja segatud 1 spl õliga		
	Madal (C)	800 g väikeseid, kooritud kartuleid, mis on segatud 1 spl õliga		
Einevariant 2: sea sisefilee / küpsetatud kartulid / köögiviljasegu	Vasak (A)	2 marineeritud veise sisefileed, lõigatud neljaks võrdseks tükiks	1. Küpsetage koorega kartuleid 12 minutit 180°C juures. 2. Lisage köögiviljad madalale astmele ja sisefilee vasakule küljele ning praadige koos 15 minutit 180°C juures. Segage köögivilju üks kord küpsetamise ajal.	
	Parem (B)	4 keskmise suurusega jahust kartulit		
	Madal (C)	800 g köögiviljasegu, mis on lõigatud 1,5 cm tükkideks ja segatud 1 spl õliga		

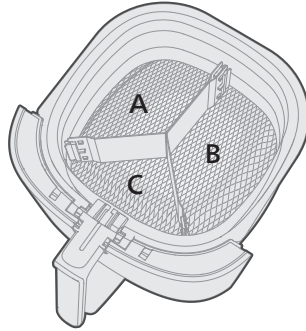

Road	Hoiustus	Koostisained		
Kala ja friikartulid	Vasak (A)	4 tükki kala maisihelveste paneeringus	<p>1. Asetage friikartulid korvi ja praadige 15 minutit 180°C juures.</p> <p>2. Raputage ja libistage friikartulid pannijagajaga korvi paremale küljele. Lisage vasakule poolele 4 kalatükki ja praadige 12 minutit 180°C juures ning keerake kala poole küpsetusaja pealt ümber.</p>	
	Parem (B)	1,2 kg külmutatud friikartuleid		
Einevariant 3: rostbiif köögiviljade ja kartulitega	Vasak (A)	Suur, alates 900 g rostbiif	<p>1. Lisage vasakule rostbiif ja paigaldage temperatuuriandur ning programmeerige fritüür 50/55/60°C peale.</p> <p>2. Poole küpsetusaja möödudes lisage köögiviljad madalale astmele ja kartulid paremale küljele, kuni temperatuur on saavutatud.</p>	
	Parem (B)	800 g kartulilootsikud		
	Madal (C)	700 g hakitud köögiviljad		
Friikartulid ja suupisted	Vasak (A)	4 kananagitsat	<p>1. Praadige kõike koos 180°C juures, kuni toit on krõbe.</p>	
	Parem (B)	800 g kartulikuubikud		
	Madal (C)	Taimetoidusuupisted: seened krõbeda koorikuga		
Taimetoidul põhinev aasiapärase suupisteeine	Vasak (A)	400 g marineeritud krabisuupisteid, 2 cm	<p>1. Lisage vasakule krabisuupisted, paremale kevadrullid ja tofuvadad ning praadige 12 minutit 180°C juures.</p> <p>2. Lisage kreekerid madalale ja praadige koos 180°C juures 4 minutit, kuni toit muutub krõbedaks.</p>	
	Parem (B)	500 g taimetoidu kevadrulle + 4 taimetoidu tofuvarrast		
	Madal (C)	100 g udangi kreekreid		



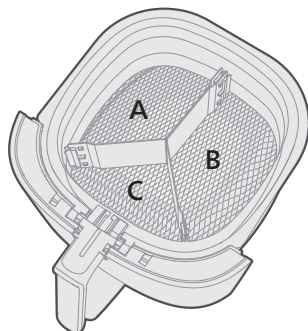

Ruokalajit	Lokero	Aineet		
Aamiainen	Vasen (A)	5 kananmunaa	8–9 min	160°C
	Oikea (B)	5 leipää tai 5 voisarvea		
	Matala (C)	4 paahtoleipäviipaletta		
Englantilainen aamiainen	Vasen (A)	4 pientä makkaraa + 4 laardiviipaletta	10–11 min	180°C
	Oikea (B)	4 kohokasta muffinivuoissa		
	Matala (C)	4 paahtoleipäviipaletta		
Aterivaihtoehto 1: 1 kananrinta / pienet perunat / vihannessekoitus	Vasen (A)	4 pientä luomukananrintaa	22–25 min, 180°C Valinnainen: käytä lämpötila-anturia ja asetta lämpötila 73°C:een, jotta saat koko aterian valmistettua kerralla.	
	Oikea (B)	900 g pilkottuja vihanneksia, jotka on leikattu 1,5 cm:n paloiksi, sekoitettuna 1 ruokalusikalliseen öljyä		
	Matala (C)	800 g pieniä, kuorittuja perunoita sekoitettuna 1 ruokalusikalliseen öljyä		
Aterivaihtoehto 2: porsaan sisäfilee / kypsennetyt perunat / vihannessekoitus	Vasen (A)	2 marinoitua porsaan sisäfilettä, jotka on puolitettu neljäksi samankokoiseksi kappaleeksi	1. Kypsennä perunoita kuorineen 12 minuuttia 180°C:ssa. 2. Lisää vihannekset matalaan lokeroon ja sisäfileet vasempaan lokeroon. Paista yhdessä 15 minuuttia 180°C:ssa ja sekoita vihanneksia kerran kypsennyksen aikana.	
	Oikea (B)	4 keskikokoista jauhoista perunaa		
	Matala (C)	800 g vihannessekoitusta 1,5 cm:n paloina sekoitettuna 1 ruokalusikalliseen öljyä		



Ruokalajit	Lokero	Aineet		
Fish & Chips	Vasen (A)	4 leivitettyä kalapalaa	<ol style="list-style-type: none"> 1. Aseta ranskanperunat koriin ja paista 15 minuuttia 180°C:ssa. 2. Ravista ranskanperunoita ja liu'uta ne korin oikeaan laitaan pannun jakajan avulla. Lisää vasemmalle puolelle 4 kalapalaa ja paista 12 minuuttia 180°C:ssa ja vaihda kalojen paistopuolta kypsennyksen puolivälissä. 	
	Oikea (B)	1,2 kg pakasteranskanperunoita		
Aterivaihtoehto 3: paahtopaistia vihanneksilla ja perunoilla	Vasen (A)	Suuri paahtopaisti, 900 g ja isommat	<ol style="list-style-type: none"> 1. Lisää paahtopaisti vasempaan lokeroon ja lisää lämpötila-anturi. Aseta lämpötila-asetukseksi 50/55/60°C. 2. Lisää vihannekset matalaan lokeroon ja perunat oikeaan lokeroon kypsennyksen puolivälissä ja tarkkaile lämpötilaa. 	
	Oikea (B)	800 g lohkopperunoita		
	Matala (C)	700 g pilkottuja vihanneksia		
Ranskanperunat ja välipalat	Vasen (A)	4 kananugettia	<ol style="list-style-type: none"> 1. Paista kaikkia aineksia yhdessä 180°C:ssa niin kauan, että niistä tulee rapeita. 	
	Oikea (B)	800 g kuutioituja perunoita		
	Matala (C)	Kasvisvälipala: rapeakuoriset sienet		
Aasialaista kasvisruokaa välipalaksi	Vasen (A)	400 g marinoituja 2 cm:n rapupaloja	<ol style="list-style-type: none"> 1. Lisää rapupalat vasempaan lokeroon ja kevätkääryleet ja tofuvartaat oikeaan lokeroon ja paista 12 minuuttia 180°C:ssa. 2. Lisää keksit matalaan lokeroon ja paista aineksia yhdessä 4 minuuttia 180°C:ssa, jolloin niistä tulee rapeita. 	
	Oikea (B)	500 g kasviskevätkääryleitä + 4 kasvistofuvarrasta		
	Matala (C)	100 g udang-keksejä		



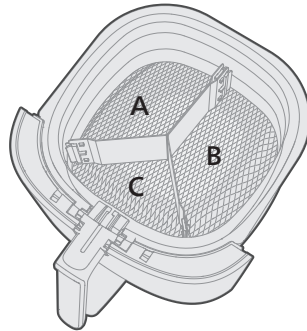

Plats	Logement	Ingrédients		
Petit-déjeuner	Gauche (A)	5 œufs	8-9 min	160°C
	Droite (B)	5 tranches de pain ou 5 croissants		
	Bas (C)	4 tranches de pain		
Petit déjeuner anglais	Gauche (A)	4 petites saucisses + 4 tranches de lard	10-11 min	180°C
	Droite (B)	4 soufflés aux œufs dans des moules à muffins		
	Bas (C)	4 tranches de pain		
Option 1 : 1 blanc de poulet / pommes de terre grenaille / macédoine de légumes	Gauche (A)	4 petits blancs de poulet bio	22-25 min, 180°C	Facultatif : utilisez la sonde de température réglée sur 73°C pour préparer le repas facilement et sans interruption.
	Droite (B)	900 g de légumes coupés en cubes de 1,5 cm, mélangés à 1 cuillère à soupe d'huile		
	Bas (C)	800 g de pommes de terre grenaille pelées et mélangées à 1 cuillère à soupe d'huile		
Option 2 : filet mignon de porc / pommes de terre au four / macédoine de légumes	Gauche (A)	2 tranches de filet mignon de porc marinées et coupées en 2, soit 4 morceaux de taille égale	1. Faites cuire les pommes de terre avec la peau pendant 12 minutes à 180°C. 2. Ajoutez les légumes dans la section du bas et le filet mignon dans la section de gauche, faites-les frire ensemble pendant 15 minutes à 180°C, en mélangeant les légumes une fois en cours de cuisson.	
	Droite (B)	4 pommes de terre moyennes à chair farineuse		
	Bas (C)	800 g de macédoine de légumes coupés en cubes de 1,5 cm et mélangés à 1 cuillère à soupe d'huile		



Plats	Logement	Ingrédients		
Fish & chips	Gauche (A)	4 portions de poisson en croûte de cornflakes	<ol style="list-style-type: none"> Placez les frites dans le panier et faites-les frire pendant 15 minutes à 180°C. Secouez, puis poussez les frites dans la section de droite du panier à l'aide du séparateur de cuve. Placez les 4 portions de poisson sur le côté gauche et faites frire pendant 12 minutes à 180°C, en retournant le poisson à mi-cuisson. 	
	Droite (B)	1,2 kg de frites surgelées		
Option 3 : rôti de bœuf accompagné de légumes et de pommes de terre	Gauche (A)	Gros rôti de bœuf d'au moins 900 g	<ol style="list-style-type: none"> Placez le rôti de bœuf à gauche, ajoutez la sonde de température et sélectionnez 50/55/60°C. À mi-cuisson, ajoutez les légumes dans la section du bas et les pommes de terre dans la section de droite jusqu'à ce que la température soit atteinte. 	
	Droite (B)	800 g de quartiers de pommes de terre		
	Bas (C)	700 g de légumes hachés		
Frites et en-cas	Gauche (A)	4 nuggets de poulet	<ol style="list-style-type: none"> Faites frire tout ensemble à 180°C jusqu'à ce que les aliments soient croustillants. 	
	Droite (B)	800 g de cubes de pommes de terre		
	Bas (C)	En-cas végétariens : champignons avec une croûte croustillante		
En-cas végétariens asiatiques	Gauche (A)	400 g de bouchées de crabe marinées de 2 cm	<ol style="list-style-type: none"> Placez les bouchées de crabe à gauche, les nems et les brochettes de tofu à droite, puis faites frire pendant 12 minutes à 180°C. Ajoutez les chips de crevette en bas et faites-les frire ensemble pendant 4 minutes à 180°C jusqu'à ce que les aliments soient croustillants. 	
	Droite (B)	500 g de nems végétariens + 4 brochettes de tofu végétariennes		
	Bas (C)	100 g de chips de crevette udang		

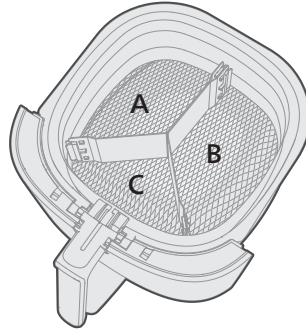

Jela	Odjeljak	Sastojci		
Doručak	Lijevi (A)	5 jaja	8 – 9 min	160°C
	Desni (B)	5 komada kruha ili 5 kroasana		
	Donji (C)	4 šnite tosta		
Engleski doručak	Lijevi (A)	4 male kobasice + 4 komada masti za doručak	10 – 11 min	180°C
	Desni (B)	4 suflea od jaja u kalupima za muffine		
	Donji (C)	4 šnite kruha za tostiranje		
1. opcija obroka: 1 komad pilećih prsa / mali krumpiri / mješavina povrća	Lijevi (A)	4 mala komada organskih pilećih prsa	22 – 25 min, 180°C Opcionalno: upotrijebite temperaturnu sondu i postavite na 73°C kako biste bez napora napravili obrok u jednom potezu.	
	Desni (B)	900 g narezanog povrća u komadima od 1,5 cm pomiješanog s 1 jušnom žlicom ulja		
	Donji (C)	800 g malih oguljenih krumpira pomiješanih s 1 jušnom žlicom ulja		
2. opcija obroka: svinjski lungić / pečeni krumpiri / mješavina povrća	Lijevi (A)	2 marinirana svinjska lungića prerezana napola na 4 jednaka komada	1. Krumpir pecite s korom 12 minuta pri 180°C. 2. Dodajte povrće u donji odjeljak, a lungić u lijevi i zajedno pržite 15 minuta pri 180°C; povrće promiješajte jednom tijekom kuhanja.	
	Desni (B)	4 brašnasta krumpira srednje veličine		
	Donji (C)	800 g miješanog povrća narezanog na komade od 1,5 cm i pomiješanog s 1 jušnom žlicom ulja		

Jela	Odjeljak	Sastojci		
Riba i krumpirići	Lijevi (A)	4 komada ribe s koricom od kukuruznih mrvica	1. Stavite krumpiriće u košaru i pržite 15 minuta pri 180°C. 2. Protresite pomaknite krumpiriće na desnu stranu košare s pomoću razdjelnika za posudu. Na lijevu stranu stavite 4 komada ribe i pržite 12 minuta pri 180°C, ribu okrenite kad protekne pola vremena kuhanja.	
	Desni (B)	1,2 kg zamrznutih krumpirića		
3. opcija obroka: rostbif s povrćem i krumpirima	Lijevi (A)	Veliki rostbif od 900 g	1. Stavite rostbif u lijevi odjeljak te dodajte temperaturnu sondu i programirajte na 50/55/60°C. 2. Kad istekne pola vremena kuhanja, dodajte povrće u donji odjeljak, a krumpir u desni dok se ne dosegne temperatura.	
	Desni (B)	800 g kriški krumpira		
	Donji (C)	700 g narezanog povrća		
Krumpirići i međuobroci	Lijevi (A)	4 pileća medaljona.	1. Pržite sve zajedno pri 180°C dok ne postane hrskavo.	
	Desni (B)	800 g kockica krumpira		
	Donji (C)	Vegetarijanski međuobroci: gljive s hrskavom koricom		
Vegetarijanski azijski međuobroci	Lijevi (A)	400 g mariniranih zalogajčića od rakova od 2 cm	1. Zalogajčiće od rakova stavite u lijevi odjeljak, a proljetne rollice i ražnjiće od tofua u desni te pržite 12 minuta pri 180°C. 2. Dodajte krekeru u donji odjeljak i pržite zajedno 4 minute pri 180°C dok hrana ne postane hrskava.	
	Desni (B)	500 g vegetarijanskih proljetnih rollica + 4 vegetarijanska ražnjića od tofua		
	Donji (C)	100 g krekeru od škampa		



Étel	Rekesz	Alapanyagok		
Reggeli	Bal (A)	5 tojás	8–9 perc	160 °C
	Jobb (B)	5 szelet kenyér vagy 5 kifli		
	Alsó (C)	4 szelet toast kenyér		
Angol reggeli	Bal (A)	4 kis méretű kolbász + 4 adag zsír	10–11 perc	180°C
	Jobb (B)	4 tojásfelfújt muffinkehelyben		
	Alsó (C)	4 szelet toast kenyér		
1. ételvariáció: 1 csirkemell/ kis burgonyák/ zöldségkeverék	Bal (A)	4 kis méretű bio csirkemell	22–25 perc, 180°C Opcionális: a hőmérséklet-érzékelő segítségével állítsa be 73°C-ra a hőmérsékletet az étel egy menetben való, egyszerű elkészítéséhez.	
	Jobb (B)	900 g aprított zöldség, 1,5 cm-es darabokra vágva, 1 evőkanál olajjal elkeverve		
	Alsó (C)	800 g kis méretű, hámozott burgonya 1 evőkanál olajjal elkeverve		
2. ételvariáció: sertés szűzpecsenye/ sült burgonya/ zöldségkeverék	Bal (A)	2 pácolt sertés szűzpecsenye, félbe vágva (4 egyforma darabra)	1. Süsse a burgonyát a héjával együtt 12 percig 180°C-on. 2. Helyezze a zöldséget az alsó rekeszbe, a szűzpecsenyét a bal oldali rekeszbe, és süsse együtt őket 15 percig 180°C-on. Sütés közben egyszer keverje meg a zöldséget.	
	Jobb (B)	4 közepes méretű lisztes burgonya		
	Alsó (C)	800 g zöldségkeverék, 1,5 cm-es darabokra vágva, 1 evőkanál olajjal elkeverve		

Étel	Rekesz	Alapanyagok		
Sült hal sült burgonyával	Bal (A)	4 hal kukoricapelyhes panírban		
	Jobb (B)	1,2 kg fagyasztott hasábburgonya		
3. ételvariáció: marhasült zöldséggel és burgonyával	Bal (A)	Nagy marhahátszín, 900 g		
	Jobb (B)	800 g steakburgonya		
	Alsó (C)	700 g aprított zöldség		
Sült ételek	Bal (A)	4 csirkefalat.		
	Jobb (B)	800 g burgonyakocka		
	Alsó (C)	Vegetáriánus falatok – gomba ropogós panírban		
Vegetáriánus ázsiai falatok	Bal (A)	400 g, 2 cm-es pácolt rákfalatok		
	Jobb (B)	500 g vegetáriánus tavaszi tekercs + 4 vegetáriánus tofunyárs		
	Alsó (C)	100 g rákszirom		

- Helyezze a burgonyahasábokat a kosárba, és süsse 15 percig 180°C-on.
- Rázza meg és a sütőedény-elválasztóval csúsztassa a burgonyát a rekesz jobb oldalába. A bal oldali rekeszbe tegye be a 4 halat, és süsse őket 12 percig 180°C-on, a sütési idő felénél fordítsa meg őket.



- Tegye a marhahátszín a bal oldali rekeszbe, majd helyezze be a hőmérséklet-érzékelőt, és állítsa be 50/55/60°C-ra.
- A sütési idő felénél helyezze be a zöldséget az alsó rekeszbe, a burgonyát pedig a jobb oldali rekeszbe, amíg a megfelelő hőmérsékletet el nem érik.

- Süsse az egészet együtt 180°C-on, amíg ropogóssá nem válnak.

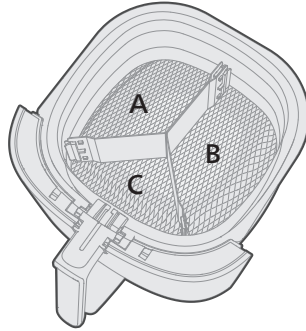
- Tegye a rákfalatoakat a bal oldali rekeszbe, a tavaszi tekerceket és a tofunyársakat pedig a jobb oldali rekeszbe, és süsse őket 12 percig 180°C-on.
- Helyezze a ráksziromot az alsó rekeszbe, és süsse a többivel együtt 4 percig 180°C-on, amíg ropogóssá nem válnak.



Hidangan	Kompartemen	Bahan-bahan		
Sarapan	Kiri (A)	5 butir telur	8–9 mnt	160°C
	Kanan (B)	5 buah roti atau 5 buah croissant		
	Bawah (C)	4 potong roti tawar		
Sarapan ala Inggris	Kiri (A)	4 buah sosis kecil + 4 iris bakon	10–11 mnt	180°C
	Kanan (B)	4 souffle telur dalam cangkir muffin		
	Bawah (C)	4 potong roti tawar		
Pilihan hidangan 1: 1 buah dada ayam / kentang kecil / sayuran campur	Kiri (A)	4 buah dada ayam organik kecil	22–25 mnt, 180°C	Opsional: gunakan probe suhu dan atur ke suhu 73°C untuk membuat hidangan sekaligus tanpa repot.
	Kanan (B)	900 g sayuran potong berukuran 1,5 cm dicampur dengan 1 sendok makan minyak		
	Bawah (C)	800 g kentang kupas kecil dicampur dengan 1 sendok makan minyak		
Pilihan hidangan 2: Babi has dalam / kentang panggang / sayuran campur	Kiri (A)	2 potong daging babi has dalam yang sudah dibumbui dan dipotong menjadi 4 bagian yang berukuran sama	1. Panggang kentang beserta kulitnya selama 12 menit pada suhu 180°C. 2. Masukkan sayuran ke dalam kompartemen bawah dan daging has dalam ke dalam kompartemen kiri, goreng selama 15 menit pada suhu 180°C, lalu aduk sayuran satu kali selama memasak.	
	Kanan (B)	4 jenis kentang yang sesuai berukuran sedang		
	Bawah (C)	800 g sayuran campur potong berukuran 1,5 cm dan dicampur dengan 1 sendok makan minyak		

Hidangan	Kompartemen	Bahan-bahan		
Ikan & Kentang Goreng	Kiri (A)	4 potong daging ikan dengan baluran serpihan keripik jagung		
	Kanan (B)	1,2 kg kentang goreng beku		
Pilihan hidangan 3: Daging sapi panggang dengan sayuran dan kentang	Kiri (A)	900 g daging sapi panggang besar		
	Kanan (B)	800 g potato wedges		
	Bawah (C)	700 g sayuran potong		
Gorengan & Camilan	Kiri (A)	4 nugget ayam		
	Kanan (B)	800 g kentang potong dadu		
	Bawah (C)	Camilan jamur vegetarian dengan baluran renyah		
Camilan vegetarian Asia	Kiri (A)	400 g crab bites berukuran 2 cm yang sudah dibumbui		
	Kanan (B)	500 g lumpia vegetarian + 4 tahu tusuk vegetarian		
	Bawah (C)	100 g kerupuk udang		



- Masukkan kentang goreng ke dalam keranjang, lalu goreng selama 15 menit pada suhu 180°C.
- Goyang dan pindahkan kentang goreng ke sisi kanan keranjang dengan pemisah pan. Masukkan 4 potong daging ikan ke dalam kompartemen kiri, goreng selama 12 menit pada suhu 180°C, dan balikkan daging di tengah proses memasak.

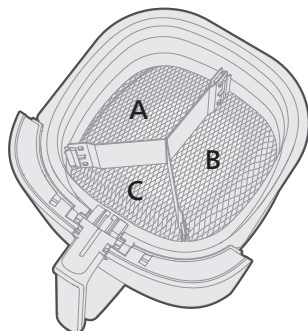

- Masukkan daging sapi panggang ke dalam kompartemen kiri, naikkan probe suhu, lalu atur ke suhu 50, 55, atau 60°C.
- Di tengah proses memasak, masukkan sayuran ke dalam kompartemen bawah dan kentang ke dalam kompartemen kanan hingga mencapai suhu yang diinginkan.

- Goreng semuanya pada suhu 180°C hingga garing.



- Masukkan crab bites ke dalam kompartemen kiri, masukkan lumpia dan tahu tusuk ke dalam kompartemen kanan, lalu goreng selama 12 menit pada suhu 180°C.
- Masukkan kerupuk ke dalam kompartemen bawah dan goreng selama 4 menit pada suhu 180°C hingga garing.



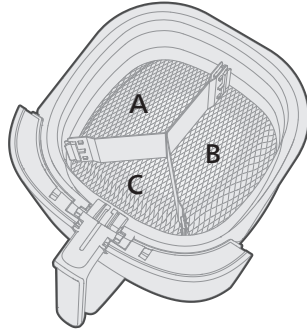

Piatti	Vano	Ingredienti		
Colazione	Sinistro (A)	5 uova	8-9 min	160°C
	Destro (B)	5 fette di pane o 5 croissant		
	Inferiore (C)	4 fette di pane per toast		
Colazione all'inglese	Sinistro (A)	4 salsicce piccole + 4 fette di lardo	10-11 min	180°C
	Destro (B)	4 uova soufflé in stampi per muffin		
	Inferiore (C)	4 fette di pane per toast		
Opzione pasto 1: 1 petto di pollo/ patate piccole/ misto di verdure	Sinistro (A)	4 piccoli petti di pollo bio	22-25 min, 180°C	Opzionale: utilizzare la sonda di temperatura e impostare a 73°C per preparare il pasto in una volta sola, senza problemi.
	Destro (B)	900 g di verdure tagliare in tocchetti di 1,5 cm e mescolare con 1 cucchiaio di olio		
	Inferiore (C)	800 g di patate piccole pelate mescolate con 1 cucchiaio di olio		
Opzione pasto 2: filetto di maiale/ patate al forno/ misto di verdure	Sinistro (A)	2 filetti di maiale marinati e tagliati a metà in 4 pezzi uguali	1. Cuocere le patate con la buccia per 12 minuti a 180°C. 2. Aggiungere le verdure nel vano inferiore e il filetto nel vano sinistro, friggere insieme per 15 minuti a 180°C e mescolare le verdure una volta durante la cottura.	
	Destro (B)	4 patate farinose di medie dimensioni		
	Inferiore (C)	800 g di verdure tagliate in tocchetti di 1,5 cm e mescolate con 1 cucchiaio di olio		
Fish & chips	Sinistro (A)	4 pezzi di pesce con crosta di cereali	1. Posizionare le patatine nel cestello e friggere per 15 minuti a 180°C. 2. Scuotere e far scorrere le patatine sul lato destro del cestello, oltre il divisore. Aggiungere 4 pezzi di pesce sul lato sinistro e friggere per 12 minuti a 180°C, girando il pesce a metà cottura.	
	Destro (B)	1,2 kg di patatine surgelate		



Piatti	Vano	Ingredienti		
Opzione pasto 3: arrosto di manzo con verdure e patate	Sinistro (A)	Grande arrosto di manzo da 900 g	<ol style="list-style-type: none"> 1. Aggiungere l'arrosto di manzo nel vano sinistro, utilizzare la sonda di temperatura e impostare a 50/55/60°C. 2. A metà del tempo di cottura, aggiungere le verdure nel vano inferiore e le patate nel vano destro, fino al raggiungimento della temperatura desiderata. 	
	Destro (B)	800 g di patate a fette		
	Inferiore (C)	700 g di verdure tagliate		
Patatine fritte e snack	Sinistro (A)	4 nugget di pollo	<ol style="list-style-type: none"> 1. Friggere tutto insieme a 180°C, finché il cibo non diventa croccante. 	
	Destro (B)	800 g di patate a cubetti		
	Inferiore (C)	Snack vegetariano ai funghi con crosta croccante		
Snack asiatico vegetariano	Sinistro (A)	400 g di bocconcini di granchio marinati, in tocchetti di 2 cm	<ol style="list-style-type: none"> 1. Aggiungere i bocconcini di granchio nel vano sinistro, gli involtini primavera e gli spiedini di tofu nel vano destro e friggere per 12 minuti a 180°C. 2. Aggiungere i cracker nel vano inferiore e friggere tutto insieme per 4 minuti a 180°C, finché il cibo non diventa croccante. 	
	Destro (B)	500 g di involtini primavera vegetariani + 4 spiedini di tofu vegetariani		
	Inferiore (C)	100 g di cracker udang		



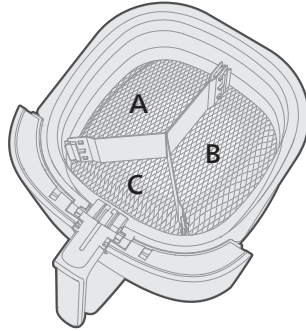

요리	수납함	재료		
아침식사	왼쪽 (A)	달걀 5개	8~9분	160°C
	오른쪽 (B)	빵 5조각 또는 크루아상 5개		
	아래쪽 (C)	토스트 4장		
영국식 아침 식사	왼쪽 (A)	작은 소시지 4개 및 조식용 라드 4개	10~11분	180°C
	오른쪽 (B)	머핀 컵 예그 수플레 4개		
	아래쪽 (C)	토스트 빵 4장		
식사 선택 1: 닭 가슴살 1조각/ 작은 감자/채소 믹스	왼쪽 (A)	유기농 닭가슴살 작은 조각 4개	22~25분, 180°C 선택 사항: 온도 조절기를 사용하여 손쉽게 한 번에 73°C 로 설정할 수 있습니다.	
	오른쪽 (B)	오일 1큰술을 넣은 1.5cm 크기로 자른 채소 900g		
	아래쪽 (C)	오일 1큰술을 넣은 껍질을 깠 작은 감자 800g		
식사 선택 2: 돼지 안심/구운 감자/ 채소 믹스	왼쪽 (A)	양념한 돼지 안심 2조각을 같은 크기의 4 조각이 되도록 절반으로 자릅니다.	1. 껍질이 있는 감자를 180°C 에서 12분 동안 굽습니다. 2. 아래쪽에는 채소를 넣고 왼쪽에는 돼지 안심을 넣습니다. 그 다음 180°C 에서 15분 동안 함께 익히고, 조리 중 채소를 한 번 뒤집어 줍니다.	
	오른쪽 (B)	중간 크기의 파슬파슬한 감자 4개		
	아래쪽 (C)	오일 1큰술을 넣은 1.5cm로 자른 채소 믹스 800g		
피시 앤 칩스	왼쪽 (A)	콘플레이크 가루를 문힌 생선 4조각	1. 감자 튀김을 바스켓에 넣고 180°C에서 15분 동안 조리합니다. 2. 감자 튀김을 흔들어 팬 분할 칸이 있는 바스켓의 오른쪽으로 모읍니다. 왼쪽에 생선 4조각을 넣고 180°C에서 12분 동안 조리합니다. 조리되는 동안 생선을 한 번 뒤집어 줍니다.	
	오른쪽 (B)	냉동 감자 튀김 1.2kg		



요리	수납함	재료		
식사 선택 3: 채소와 감자를 곁들인 비프 스테이크	왼쪽 (A)	스테이크용 소고기 900g	<ol style="list-style-type: none"> 1. 왼쪽에 스테이크용 소고기를 넣고 온도 조절기를 사용하여 50/55/60°C로 설정합니다. 2. 조리 시간의 절반이 지나면 조리 온도에 도달할 때까지 아래 칸에 채소를, 오른쪽 칸에 감자를 넣습니다. 	
	오른쪽 (B)	웨이 감자 800g		
	아래쪽 (C)	자른 채소 700g		
감자 튀김 및 간식	왼쪽 (A)	치킨 너겟 4조각	<ol style="list-style-type: none"> 1. 바삭해질 때까지 모든 재료를 180°C에서 함께 조리합니다. 	
	오른쪽 (B)	네모 모양으로 자른 감자 800g		
	아래쪽 (C)	채식 간식: 곁을 바삭하게 익힌 버섯		
아시안 채식 간식 시간	왼쪽 (A)	양념한 게살을 2cm 크기로 뭉친 경단 400g	<ol style="list-style-type: none"> 1. 왼쪽에 게살 경단을, 오른쪽에 스프링롤과 두부 꼬치를 넣은 다음 180°C에서 12분 동안 조리합니다. 2. 아래쪽에 크래커를 넣고 재료들이 바삭해질 때까지 180°C에서 4분 동안 함께 조리합니다. 	
	오른쪽 (B)	채식 스프링롤 500g 및 채식 두부 꼬치 4개		
	아래쪽 (C)	우당 크래커 100g		



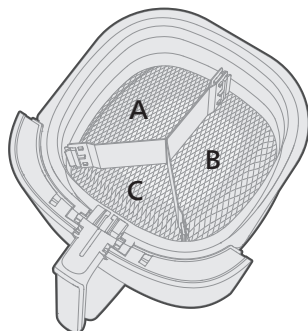

Patiekalai	Skyrius	Produktai		
Pusryčiai	Kairioji (A)	5 kiaušiniai	8–9 min.	160°C
	Dešinė (B)	5 duonos gabalėliai arba 5 kruasanai		
	Neryšku (C)	4 skrebučių riekelės		
Angliški pusryčiai	Kairioji (A)	4 mažos dešrelės + 4 gabaliukai lašiniai pusryčiams	10–11 min.	180°C
	Dešinė (B)	4 kiaušinių suflė keksiukų kaušeliuose		
	Neryšku (C)	4 skrudintos duonos riekelės		
1 patiekalo variantas: 1 vištienos krūtinėlė / mažos bulvytės / daržovių mišinys	Kairioji (A)	4 nedidelės ekologiškos vištienos krūtinėlės	22–25 min. 180°C temperatūroje	Pasirinktinai: naudokite temperatūros zondą ir nustatykite 73°C temperatūrą, kad patiekalą pagamintumėte vienu ypu be vargo.
	Dešinė (B)	900 g 1,5 cm storio pjaustytų daržovių, sumaišytų su 1 valgomuoju šaukštu aliejaus		
	Neryšku (C)	800 g mažų, nuluptų bulvyčių, sumaišytų su 1 valgomuoju šaukštu aliejaus		
2 patiekalo variantas: kiaulienos nugarinė / keptos bulvės / daržovių mišinys	Kairioji (A)	2 kiaulienos nugarinės, marinuotos ir perpjautos per pusę į 4 vienodus gabalėlius	1. Kepkite bulves su odele 12 minučių 180°C temperatūroje. 2. Į apatinį indą sudėkite daržoves, į kairįjį – nugarinę ir kepkite kartu 15 min. 180°C temperatūroje; kepimo metu daržoves vieną kartą pamašykite.	
	Dešinė (B)	4 vidutinio dydžio krakmolingos bulvės		
	Neryšku (C)	800 g daržovių mišinio, supjaustyto 1,5 cm gabalėliais ir sumaišyto su 1 valgomuoju šaukštu aliejaus		

Patiekalai	Skyrius	Produktai		
Žuvis ir gruzdintos bulvytės	Kairioji (A)	4 žuvis gabaliukai su kukurūzų dribsnių plutele	<ol style="list-style-type: none"> 1. Sudėkite bulvytes į krepšelį ir kepkite 15 minučių 180°C temperatūroje. 2. Bulvytes pakratykite ir keptuvės pertvara perkeltkite į dešinę krepšelio pusę. Kairėje pusėje sudėkite 4 žuvis gabalėlius ir kepkite 12 minučių 180°C temperatūroje, įpusėjus kepimo laikui žuvį apverskite. 	
	Dešinė (B)	1,2 kg šaldytų bulvyčių		
3 patiekalo variantas: jautienos kepsnys su daržovėmis ir bulvėmis	Kairioji (A)	Didelis jautienos kepsnys nuo 900 g	<ol style="list-style-type: none"> 1. Į kairįjį indą įdėkite jautienos kepsnį, įdėkite temperatūros sondą ir užprogramuokite 50 / 55 / 60°C. 2. Įpusėjus kepimo laikui, į apatinį indą įdėkite daržoves, o į dešinįjį – bulves, kol pasieksite nustatytą temperatūrą. 	
	Dešinė (B)	800 g bulvių skiltelių		
	Neryšku (C)	700 g pjaustytų daržovių		
Gruzdintos bulvytės ir užkandžiai	Kairioji (A)	4 vištienos grynuoliai.	<ol style="list-style-type: none"> 1. Kepkite viską kartu 180°C temperatūroje, kol maistas taps traškus. 	
	Dešinė (B)	800 g bulvių kubelių		
	Neryšku (C)	Vegetariški užkandžiai: grybai su traškia plutele		
Vegetariški azijietiški užkandžiai	Kairioji (A)	400 g 2 cm ilgio marinuotų krabų kąsnelių	<ol style="list-style-type: none"> 1. Į kairįjį indą sudėkite krabų kąsnelius, į dešinįjį – suktinukus ir tofu iešmelius, ir kepkite 12 min. 180°C temperatūroje. 2. Į apatinį indą sudėkite krekerius ir kepkite kartu 4 minutes 180°C temperatūroje, kol maistas taps traškus. 	
	Dešinė (B)	500 g vegetariškų suktinukų ir 4 vegetariški tofu iešmeliai		
	Neryšku (C)	100 g <i>udang</i> krekerių		



Ēdieni	Nodalījums	Sastāvdaļas		
Brokastis	Kreisā puse (A)	5 olas	8–9 min	160°C
	Labā puse (B)	5 maizītes vai 5 kruasāni		
	Zema (C)	4 tostermaizes šķēles		
Angļu brokastis	Kreisā puse (A)	4 mazās desiņas + 4 gab. brokastu bekona	10–11 min	180°C
	Labā puse (B)	4 olu suflē kēksiņu formiņās		
	Zema (C)	4 tostermaizes šķēles		
1. maltītes variants: 1 vistas fileja / mazie kartupeliši / dārzeņu maisījums	Kreisā puse (A)	4 nelielas bioloģiski audzētu vistu filejas	22–25 min, 180°C	Pēc izvēles: izmantojiet temperatūras zondi un iestatiet 73°C temperatūru, lai viegli pagatavotu maltīti vienā piegājienā.
	Labā puse (B)	900 g dārzeņu, sagriezti 1,5 cm kubiņos un sajaukti ar 1 ēdamkaroti eļļas		
	Zema (C)	800 g nelielu mizotu kartupeļu, sajaukti ar 1 ēdamkaroti eļļas		
2. maltītes variants: cūkgaļas fileja / cepti kartupeļi / dārzeņu maisījums	Kreisā puse (A)	2 gab. marinētas cūkgaļas filejas, sagriezta uz pusēm 4 vienādās daļās	1. Cepiet kartupeļus ar mizu 12 minūtes 180°C temperatūrā. 2. Pievienojiet dārzeņus apakšējā nodalījumā un cūkgaļas fileju kreisajā nodalījumā un cepiet kopā 15 minūtes 180°C temperatūrā, vienu reizi gatavošanas laikā apmaisot dārzeņus.	
	Labā puse (B)	4 vidēji lieli miltaini kartupeļi		
	Zema (C)	800 g dārzeņu maisījuma, sagriezti 1,5 cm gabaliņos un sajaukti ar 1 ēdamkaroti eļļas		

Ēdieni	Nodalījums	Sastāvdaļas		
Cepta zivs ar fritētiem kartupeļiem	Kreisā puse (A)	4 zivs gabaliņi kukurūzas pārslu panējumā		
	Labā puse (B)	1,2 kg saldētu fritētu kartupeļu		
3. maltītes variants: rostbifs ar dārzeņiem un kartupeļiem	Kreisā puse (A)	Liels rostbifs no 900 g liellopa gaļas		
	Labā puse (B)	800 g kartupeļu daiviņu		
	Zema (C)	700 g sagrieztu dārzeņu		
Fritēti kartupeļi un uzkodas	Kreisā puse (A)	4 vistas gaļas gabaliņi panējumā.		
	Labā puse (B)	800 g kartupeļu kubiņu		
	Zema (C)	Veģetārās uzkodas: sēnes ar kraukšķīgu garoziņu		
Veģetārās uzkodas Āzijas gaumē	Kreisā puse (A)	400 g marinētu krabja gaļas gabaliņu, 2 cm		
	Labā puse (B)	500 g veģetāro pavasara rulliņu + 4 veģetārie tofu iesmiņi		
	Zema (C)	100 g garneļu krekeru		

1. Ievietojiet fritētos kartupeļus grozā un cepiet 15 minūtes 180°C temperatūrā.

2. Sakratiet un pārbīdiet fritētos kartupeļus uz groza labo pusi, izmantojot pannas sadalītāju. Kreisajā pusē ievietojiet 4 gabaliņus zivs un cepiet 12 minūtes 180°C temperatūrā, gatavošanas laika vidū apgrieziet zivs gabaliņus otrādi.

1. Ievietojiet liellopa gaļu kreisajā pusē, pievienojiet temperatūras zondi un programmai iestatiet 50/55/60°C temperatūru.

2. Gatavošanas laika vidū ievietojiet dārzeņus apakšējā nodalījumā un kartupeļus labajā nodalījumā, līdz tiek sasniegta vajadzīgā temperatūra.

1. Cepiet visu kopā 180°C temperatūrā, līdz ēdiens kļūst kraukšķīgs.

1. Ievietojiet krabja gaļas gabaliņus kreisajā pusē, bet pavasara rulliņus un tofu iesmiņus labajā pusē un cepiet 12 minūtes 180°C temperatūrā.

2. Ievietojiet krekerus apakšējā nodalījumā un cepiet kopā 4 minūtes 180°C temperatūrā, līdz ēdiens kļūst kraukšķīgs.

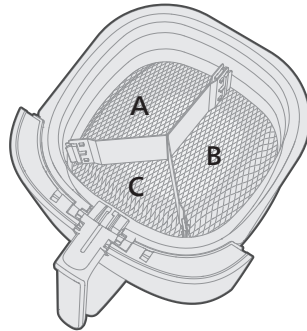



Јадења	Преграда	Состојки		
Појадок	Лева (А)	5 јајца	8-9 мин.	160°C
	Десна (В)	5 парчиња леб или 5 кроасани		
	Долна (С)	4 парчиња тост		
Англиски појадок	Лева (А)	4 мали колбаси + 4 парчиња свинска маст за појадок	10-11 мин.	180°C
	Десна (В)	4 суфлеа од јајца во калапи за мафини		
	Долна (С)	4 парчиња тост		
Опција за оброк 1: 1 парче пилешки гради / мали компири / мешан зеленчук	Лева (А)	4 мали органски пилешки гради	22-25 мин., 180°C	Изборно: користете ја сондата за температура и поставете на 73°C за лесно да го подготвите оброкот во еден процес.
	Десна (В)	900 г сечкан зеленчук исечкан на 1,5 cm измешан со 1 супена лажица масло		
	Долна (С)	800 г мали, излупени компири измешани со 1 супена лажица масло		
Опција за оброк 2: свинско филе / печени компири / мешан зеленчук	Лева (А)	2 парчиња свинско филе маринирани и исечени на половина на 4 еднакви парчиња	1. Печете ги компирите со лушпа 12 минути на 180°C. 2. Додадете зеленчук во Долната преграда и филе во Левата преграда и пржете заедно 15 минути на 180°C и еднаш промешајте го зеленчукот за време на готвењето.	
	Десна (В)	4 брашнести компири со средна големина		
	Долна (С)	800 г мешан зеленчук исечкан на 1,5 cm и измешан со 1 супена лажица масло		

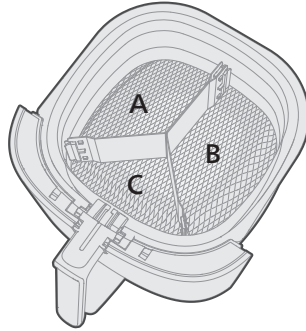

Јадења	Преграда	Состојки		
Риба и помфрит	Лева (А)	4 парчиња риба со кора од корнфлекс	<ol style="list-style-type: none"> 1. Помфритот ставете го во корпата и пржете 15 минути на 180°C. 2. Протресете и поместете го помфритот на десната страна од корпата со разделникот на садот. На левата страна додајте 4 парчиња риба и пржете 12 минути на 180°C, па превртете ја рибата кога ќе измине половина од времето на готвење. 	
	Десна (В)	1,2 kg замрзнат помфрит		
Опција за оброк 3: печено говедско месо со зеленчук и компири	Лева (А)	Големо печено говедско месо од 900 g	<ol style="list-style-type: none"> 1. Додајте печено говедско месо во Левата преграда, додајте сонда за температура и поставете на 50/55/60°C. 2. Кога ќе измине половина од времето на готвење, додајте зеленчук во Долната преграда и компири во Десната преграда сè додека не се постигне температурата. 	
	Десна (В)	800 g пекарски компир		
	Долна (С)	700 g сечкан зеленчук		
Помфрит и закуски	Лева (А)	4 пилешки медалјони.	<ol style="list-style-type: none"> 1. Пржете се заедно на 180°C сè додека храната не стане крцкава. 	
	Десна (В)	800 g компир исечкан на коцки		
	Долна (С)	Вегетаријански закуски - печурки со крцкава кора		
Вегетаријански азиски закуски	Лева (А)	400 g мариинирани парчиња ракчиња од 2 cm	<ol style="list-style-type: none"> 1. Додајте ги парчињата ракчиња во Левата преграда, а пролетните ролнички и раженчињата со тофу во Десната преграда и пржете 12 минути на 180°C. 2. Додајте крекери во Долната преграда и пржете заедно 4 минути на 180°C сè додека храната не стане крцкава. 	
	Десна (В)	500 g вегетаријански пролетни ролнички + 4 вегетаријански раженчиња со тофу		
	Долна (С)	100 g крекери од шампи		



Sajian	Petak	Ramuan		
Sarapan pagi	Kiri (A)	5 telur	8–9 min	160°C
	Kanan (B)	5 keping roti atau 5 kroisan		
	Rendah (C)	4 keping roti bakar		
Sarapan ala Inggeris	Kiri (A)	4 sosej kecil + 4 sudu besar minyak	10–11 min	180°C
	Kanan (B)	4 sufle telur di dalam cawan muffin		
	Rendah (C)	4 keping roti bakar		
Pilihan hidangan 1: 1 dada ayam / ubi kentang kecil / sayur campuran	Kiri (A)	4 keping dada ayam yang kecil	22–25 min, 180°C	Pilihan: gunakan jarum suhu dan tetapkan kepada 73°C untuk membuat hidangan sekali gus.
	Kanan (B)	900 g sayuran yang dicincang dalam ukuran 1.5 cm dan dicampurkan dengan 1 sudu besar minyak		
	Rendah (C)	800 g ubi kentang kecil yang telah dikupas dan dicampurkan dengan 1 sudu besar minyak		
Pilihan hidangan 2: Daging batang pinang / kentang bakar / sayur campuran	Kiri (A)	2 daging batang pinang yang telah diperap dan dipotong dua atau 4 kepingan yang sama	1. Bakar ubi kentang dengan kulit selama 12 minit pada suhu 180°C. 2. Tambahkan sayur di dalam petak Rendah dan daging di dalam petak Kiri dan goreng bersama-sama selama 15 minit pada suhu 180°C dan kacau sayur sekali semasa memasak.	
	Kanan (B)	4 ubi kentang gebu bersaiz sederhana		
	Rendah (C)	800 g potongan sayur campuran yang dipotong dalam ukuran 1.5 cm dan dicampurkan dengan 1 sudu besar minyak		

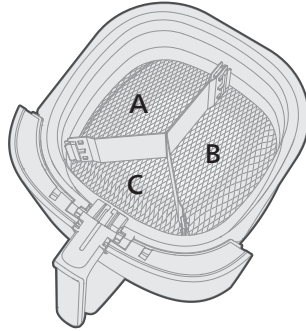

Sajian	Petak	Ramuan		
Ikan & Kentang Goreng	Kiri (A)	4 keping ikan dengan serbuk emping jagung	<ol style="list-style-type: none"> 1. Letakkan kentang jejari di dalam bakul dan goreng selama 15 minit pada suhu 180°C. 2. Goncang dan tolakkan kentang jejari ke sebelah kanan bakul dengan pembahagi kualiti. Di sebelah kiri, tambahkan 4 keping ikan dan goreng selama 12 minit pada suhu 180°C dan terbalikkan ikan pada separuh masa memasak. 	
	Kanan (B)	1.2 kg kentang jejari beku		
Pilihan hidangan 3: Daging lembu panggang dengan sayuran dan ubi kentang	Kiri (A)	Daging lembu panggang yang lebih besar daripada 900 g	<ol style="list-style-type: none"> 1. Tambahkan daging lembu panggang di dalam petak Kiri dan masukkan jarum suhu dan tetapkan kepada 50/55/60°C. 2. Pada separuh masa memasak, tambahkan sayuran di dalam petak Rendah dan ubi kentang di dalam petak Kanan sehingga suhu tercapai. 	
	Kanan (B)	800 g bebaji kentang		
	Rendah (C)	700 g sayuran yang dicincang		
Kentang Jejari & Snek	Kiri (A)	4 nuget ayam.	<ol style="list-style-type: none"> 1. Goreng semua bahan bersama-sama pada suhu 180°C sehingga menjadi rangup. 	
	Kanan (B)	800 g kiub ubi kentang		
	Rendah (C)	Snek vegetarian - cendawan rangup		
Waktu snek Asia vegetarian	Kiri (A)	400 g ketulan isi ketam yang telah diperap dalam ukuran 2 cm	<ol style="list-style-type: none"> 1. Tambahkan ketulan isi ketam di dalam petak Kiri dan popia dan sate tauhu di dalam petak Kanan, dan goreng selama 12 minit pada suhu 180°C. 2. Tambahkan keropok di dalam petak Rendah dan goreng bersama-sama selama 4 minit pada suhu 180°C sehingga menjadi rangup. 	
	Kanan (B)	500 g popia sayur + 4 sate tauhu vegetarian		
	Rendah (C)	100 g keropok udang		



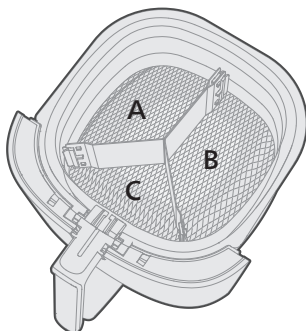

Gerechten	Compartment	Ingrediënten		
Ontbijt	Links (A)	5 eieren	8-9 min	160°C
	Rechts (B)	5 kleine sneetjes brood of 5 croissants		
	Laag (C)	4 sneetjes brood		
English Breakfast	Links (A)	4 kleine worstjes + 4 stukjes ontbijtspek	10-11 min	180°C
	Rechts (B)	4 eiersoufflés in muffinvormen		
	Laag (C)	4 sneetjes geroosterd brood		
Maaltijdoptie 1: 1 kipfilet / kleine aardappelen / groentemix	Links (A)	4 kleine biologische kipfilets	22-25 min, 180°C	Optioneel: gebruik de temperatuursensor en stel deze in op 73°C om de maaltijd eenvoudig in één keer te bereiden.
	Rechts (B)	900 g gehakte groenten gesneden in 1.5 cm, gemengd met 1 eetlepel olie		
	Laag (C)	800 g kleine, geschilde aardappelen, gemengd met 1 eetlepel olie		
Maaltijdoptie 2: varkenshaas / gebakken aardappelen / groentemix	Links (A)	2 gemarineerde varkenshaasjes, doormidden gesneden tot 4 gelijke stukken	1. Bak de aardappelen met de huid gedurende 12 minuten op 180°C. 2. Voeg de groenten toe in het onderste compartiment en de ossenhaas in het linker en bak samen gedurende 15 minuten op 180°C. Roer de groenten één keer om tijdens het koken.	
	Rechts (B)	Middelgrote kruimige aardappelen		
	Laag (C)	800 g groentemix, gesneden in stukjes van 1,5 cm en gemengd met 1 eetlepel olie		



Gerechten	Compartiment	Ingrediënten		
Fish and chips	Links (A)	4 stukken vis met een cornflakekorst	<ol style="list-style-type: none"> 1. Doe de frites in het mandje en bak ze 15 minuten op 180°C. 2. Schud en schuif de frites naar de rechterkant van het mandje met de panverdelers. Leg in het linkse compartiment 4 stukken vis en bak ze 12 minuten op 180°C. Draai de vis halverwege de bereidingstijd om. 	
	Rechts (B)	1,2 kg bevroren frites		
Maaltijdoptie 3: rosbief met groenten en aardappelen	Links (A)	Grote rosbief van 900 gram	<ol style="list-style-type: none"> 1. Leg de rosbief in het linkse compartiment, voeg de temperatuursensor toe en programmeer deze op 50/55/60°C. 2. Voeg halverwege de bereidingstijd groenten toe in het onderste compartiment en aardappelen in het rechtse compartiment totdat de temperatuur is bereikt. 	
	Rechts (B)	800 g aardappelpartjes		
	Laag (C)	700 g gehakte groenten		
Frites en snacks	Links (A)	4 kipnuggets.	<ol style="list-style-type: none"> 1. Bak alles samen op 180°C tot het voedsel krokant wordt. 	
	Rechts (B)	800 g aardappelblokjes		
	Laag (C)	Vegetarische snacks: champignons met knapperige korst		
Kooktijd vegetarische Aziatische snack	Links (A)	400 g gemarineerde krabbetjes van 2 cm	<ol style="list-style-type: none"> 1. Voeg de krabbetjes toe in het linker compartiment en lentebroodjes en tofuspiesen in het rechtse compartiment, en bak 12 minuten op 180°C. 2. Voeg kroepoek toe in het onderste compartiment en bak samen 4 minuten op 180°C tot het voedsel krokant wordt. 	
	Rechts (B)	500 g vegetarische loempia's + 4 vegetarische tofu-spiesen		
	Laag (C)	100 g udang-kroepoek		



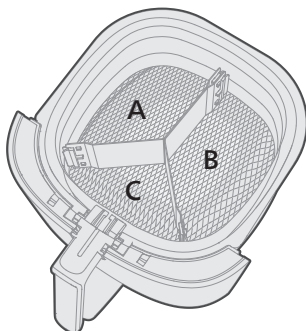

Retter	Rom	Ingredienser		
Frokost	Venstre del (A)	5 egg	8–9 min	160°C
	Høyre del (B)	5 stykker brød eller 5 croissanter		
	Underdel (C)	4 skiver toast		
Engelsk frokost	Venstre del (A)	4 små pølser + 4 stykker frokostsmult	10–11 min	180°C
	Høyre del (B)	4 eggsuffleer i muffinskopper		
	Underdel (C)	4 skiver toast		
Måltidsalternativ 1: 1 kyllingbryst / småpoteter / grønnsaksblanding	Venstre del (A)	4 små økologiske kyllingbryst	22–25 min, 180°C Valgfritt: Bruk temperaturproben og innstill på 73°C for å lage hele måltidet på en gang uten problemer.	
	Høyre del (B)	900 g hakkede grønnsaker kuttet i 1,5 cm blandet med 1 ss olje		
	Underdel (C)	800 g små, skrelte poteter blandet med 1 ss olje		
Måltidsalternativ 2: indrefilet av svin / bakte poteter / grønnsaksblanding	Venstre del (A)	2 indrefilet av svin marineres og kuttes i to til 4 like deler	1. Stek poteter med skallet på i 12 minutter på 180°C. 2. Ha i grønnsaker i underdel og indrefilet i venstre del, stek sammen i 15 minutter på 180°C, og rør grønnsakene en gang under matlagingen.	
	Høyre del (B)	4 middels store melne poteter		
	Underdel (C)	800 g grønnsaksblanding kuttet i 1,5 cm og blandet med 1 ss olje		



Retter	Rom	Ingredienser		
Fish & Chips	Venstre del (A)	4 stykker fisk med en cornflakesskorpe	<ol style="list-style-type: none"> Legg pomes frites i kurven og stek i 15 minutter på 180°C. Rist og skyv pomes frites til høyre del av kurven med skilleveggen. Ha i 4 stykker fisk i venstre del, stek i 12 minutter på 180°C og snu fisken halvveis gjennom tilberedningstiden. 	
	Høyre del (B)	1,2 kg frysede pomes frites		
Måltidsalternativ 3: Roastbiff med grønnsaker og poteter	Venstre del (A)	Stor roastbiff på 900 g	<ol style="list-style-type: none"> Ha i roastbiff i venstre del og tilsett temperaturprobe og innstill på 50/55/60°C. Halvveis gjennom tilberedningstiden tilsetter du grønnsaker i underdel og poteter i høyre del frem til temperaturen er nådd. 	
	Høyre del (B)	800 g potetbåter		
	Underdel (C)	700 g hakkede grønnsaker		
Pomes frites og snacks	Venstre del (A)	4 kyllingnuggets.	<ol style="list-style-type: none"> Stek alt sammen på 180°C til maten blir sprø. 	
	Høyre del (B)	800 g potetterninger		
	Underdel (C)	Vegetarisk snacks – sopp med knasende skorpe		
Vegetarisk asiatisk snacktid	Venstre del (A)	400 g marinerte krabbebiter på 2 cm	<ol style="list-style-type: none"> Ha i krabbebitene i venstre del og vårruller og tofuspyd i høyre del, og stek i 12 minutter på 180°C. Ha i kjeks i underdel og stek sammen i 4 minutter på 180°C til maten blir sprø. 	
	Høyre del (B)	500 g vegetariske vårruller + 4 vegetariske tofuspyd		
	Underdel (C)	100 g udangkjeks		



Dania	Schowek	Składniki		
Śniadanie	Lewa (A)	5 jajek	8–9 min	160°C
	Prawa (B)	5 kawałków pieczywa lub 5 croissantów		
	Dolna (C)	4 tosty		
Angielskie śniadanie	Lewa (A)	4 małe kielbaski + 4 porcje smalcu	10–11 min	180°C
	Prawa (B)	4 suflety jajeczne w foremkach do babeczek		
	Dolna (C)	4 kromki chleba tostowego		
Propozycja dania nr 1: 1 pierś z kurczaka / ziemniaczki / mieszanka warzywna	Lewa (A)	4 małe piersi z kurczaka z fermy ekologicznej	22–25 min, 180°C	Opcjonalne: użyj czujnika temperatury i ustaw go na 73°C, aby przygotować posiłek bez wysiłku i za jednym zamachem.
	Prawa (B)	900 g warzyw pokrojonych w 1,5 cm kawałki zmieszanych z łyżką oleju		
	Dolna (C)	800 g małych, obranych ziemniaków zmieszanych z jedną łyżką oleju		
Propozycja dania nr 2: polędwiczka wieprzowa / pieczone ziemniaki / mieszanka warzywna	Lewa (A)	2 polędwiczki wieprzowe zamarynowane i przekrojone na pół na 4 równe części	1. Piec ziemniaki ze skórką przez 12 minut w temperaturze 180°C. 2. Warzywa włożyć do dolnej przegrody, a polędwicę do lewej i smażyć razem przez 15 minut w temperaturze 180°C, jednorazowo mieszając warzywa podczas gotowania.	
	Prawa (B)	4 mączyste ziemniaki średniej wielkości		
	Dolna (C)	800 g mieszanki warzywnej pokrojonej w 1,5 cm kawałki i wymieszanej z 1 łyżką oleju		

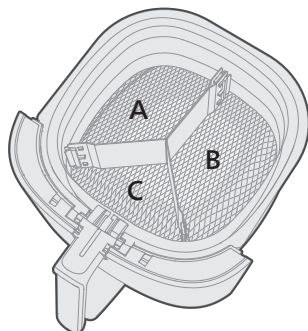

Dania	Schowek	Składniki		
Ryba z frytkami	Lewa (A)	4 kawałki ryby w panierce z płatków kukurydzianych	1. Umieść frytki w koszu i smaż przez 15 minut w temperaturze 180°C. 2. Potrząśnij koszem i przesuń frytki na jego prawą stronę, używając przekładki. Włóż do lewej przegrody 4 kawałki ryby i smaż przez 12 minut w temperaturze 180°C. Obróć rybę w połowie czasu smażenia.	
	Prawa (B)	1,2 kg mrożonych frytek		
Propozycja dania nr 3: pieczeń wołowa z warzywami i ziemniakami	Lewa (A)	Duża pieczeń wołowa o wadze co najmniej 900 g	1. Umieść pieczeń wołową w lewej przegrodzie, włóż czujnik temperatury i zaprogramuj go na 50/55/60°C. 2. W połowie czasu gotowania włóż warzywa do dolnej przegrody i ziemniaki do prawej. Poczekaj do osiągnięcia odpowiedniej temperatury.	
	Prawa (B)	800 g ćwiartek ziemniaków		
	Dolna (C)	700 g posiekanych warzyw		
Frytki i przekąski	Lewa (A)	4 kawałki kurczaka	1. Smaż wszystko razem w temperaturze 180°C, aż do osiągnięcia chrupkości.	
	Prawa (B)	800 g ziemniaków pokrojonych w kostkę		
	Dolna (C)	Wegetariańskie przekąski — grzyby w chrupiącej panierce		
Wegetariańskie azjatyckie przekąski	Lewa (A)	400 g marynowanych kawałków kraba o średnicy 2 cm	1. Dodaj kawałki kraba do lewej przegrody i sajgonki oraz szaszłyki z tofu do prawej. Smaż przez 12 minut w temperaturze 180°C. 2. Do dolnej przegrody dodaj prażynki i smaż razem przez 4 minuty w temperaturze 180°C do osiągnięcia chrupkości.	
	Prawa (B)	500 g wegetariańskich sajgonek + 4 szaszłyki z tofu		
	Dolna (C)	100 g prażynek krewetkowych		



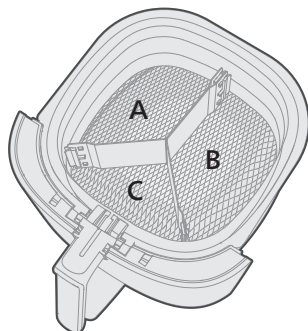

Pratos	Compartimento	Ingredientes		
Pequeno-almoço	Esquerdo (A)	5 ovos	8 – 9 min	160°C
	Direito (B)	5 unidades de pães ou 5 croissants		
	Baixo (C)	4 fatias de torradas		
Pequeno-almoço inglês	Esquerdo (A)	4 salsichas pequenas + 4 unidades de banha para pequeno-almoço	10 – 11 min	180°C
	Direito (B)	4 soufflés de ovos em chávenas para muffin		
	Baixo (C)	4 fatias de pão para torradas		
Opção de refeição 1: 1 peito de frango/batatas pequenas/mistura de vegetais	Esquerdo (A)	4 peitos de frango biológico pequenos	22 – 25 min, 180 °C	Opcional: utilize a sonda de temperatura e defina para 73 °C para preparar a refeição de uma só vez sem complicações.
	Direito (B)	900 g de vegetais cortados em 1,5 cm misturados com 1 colher de sopa de óleo		
	Baixo (C)	800 g de batatas pequenas descascadas misturadas com 1 colher de sopa de óleo		
Opção de refeição 2: lombo de porco/batatas assadas/mistura de vegetais	Esquerdo (A)	2 lombos de porco marinados e cortados ao meio em 4 pedaços iguais	1. Coza as batatas com a pele durante 12 minutos a 180 °C. 2. Junte os vegetais no compartimento de Baixo e o lombo no compartimento Esquerdo. Frite ao mesmo tempo durante uns 15 minutos a 180 °C e mexa os vegetais uma vez durante a preparação.	
	Direito (B)	4 batatas de tamanho médio		
	Baixo (C)	800 g de mistura de vegetais cortados em 1,5 cm misturados com 1 colher de sopa de óleo		



Pratos	Compartimento	Ingredientes		
Fish & Chips (Peixe e Batatas Fritas)	Esquerdo (A)	4 pedaços de peixe com uma crosta de flocos de milho	<ol style="list-style-type: none"> 1. Coloque as batatas no cesto e deixe cozinhar durante 15 minutos a 180°C. 2. Agite e deslize as batatas para o lado direito do cesto com a divisória do recipiente. Adicione 4 pedaços de peixe no lado esquerdo, frite durante 12 minutos a 180 °C e vire o peixe a meio do tempo de preparação. 	
	Direito (B)	1,2 kg de batatas fritas congeladas		
Opção de refeição 3: carne assada com vegetais e batatas	Esquerdo (A)	Carne assada (pedaço grande) com 900 g	<ol style="list-style-type: none"> 1. Adicione a carne assada no compartimento Esquerdo. Adicione a sonda de temperatura e programe na temperatura 50/55/60 °C. 2. A meio do tempo de preparação, adicione os vegetais no compartimento de Baixo e as batatas no compartimento Direito até atingir a temperatura. 	
	Direito (B)	800 g de gomos de batatas		
	Baixo (C)	700 g de vegetais cortados		
Batatas fritas e lanches	Esquerdo (A)	4 nuggets de frango.	<ol style="list-style-type: none"> 1. Frite tudo junto a 180 °C até que os alimentos fiquem crocantes. 	
	Direito (B)	800 g de cubos de batatas		
	Baixo (C)	Lanches vegetarianos - cogumelos com crosta crocante		
Hora do lanche asiático vegetariano	Esquerdo (A)	400 g de pedaços de caranguejo marinado de 2 cm	<ol style="list-style-type: none"> 1. Adicione os pedaços de caranguejo no compartimento Esquerdo, e os rolos de primavera e os espetos de tofu no compartimento Direito. Frite durante 12 minutos a 180 °C. 2. Junte as bolachas no compartimento de Baixo e frite tudo junto durante 4 minutos a 180 °C até que os alimentos fiquem crocantes. 	
	Direito (B)	500 g de rolos de primavera vegetarianos e 4 espetos de tofu vegetariano		
	Baixo (C)	100 g de bolachas udang		



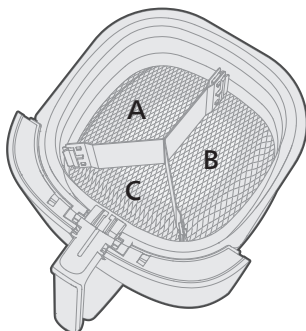

Preparate	Compartment	Ingrediente		
Mic dejun	Compartmentul din stânga (A)	5 ouă	8–9 min.	160°C
	Compartmentul din dreapta (B)	5 bucăți de pâine sau 5 croissante		
	Compartmentul de jos (C)	4 felii de pâine prăjită		
Mic dejun englezesc	Compartmentul din stânga (A)	4 cârnați mici + 4 bucăți untură pentru mic dejun	10–11 min.	180°C
	Compartmentul din dreapta (B)	4 sufleuri de ou în forme de brișe		
	Compartmentul de jos (C)	4 felii de pâine prăjită		
Opțiunea de masă 1: 1 piept de pui/ cartofi mici/ amestec de legume	Compartmentul din stânga (A)	4 piepturi mici de pui organic	22–25 min., 180°C	Opțional: utilizează sonda de temperatură și setează 73°C pentru a prepara masa dintr-o dată, fără bătăi de cap.
	Compartmentul din dreapta (B)	900 g legume tocate de 1,5 cm amestecate cu lingură de 1 ulei		
	Compartmentul de jos (C)	800 g cartofi mici, decojiți, amestecați cu 1 lingură de ulei		
Opțiunea de masă 2: mușchi de porc/cartofi copti/ amestec de legume	Compartmentul din stânga (A)	2 felii de mușchi de porc marinate și tăiate pe jumătate în 4 bucăți egale	1. Coace cartofii în coajă timp de 12 minute la 180°C. 2. Adaugă legumele jos și mușchiul în stânga și prăjește-le 15 minute la 180°C, amestecând legumele o singură dată în timpul gătirii.	
	Compartmentul din dreapta (B)	4 cartofi făinoși de dimensiuni medii		
	Compartmentul de jos (C)	800 g amestec de legume tăiate la 1,5 cm și amestecate cu 1 lingură de ulei		



Preparate	Compartiment	Ingrediente		
Pește cu cartofi prăjiți	Compartimentul din stânga (A)	4 bucăți de pește în crustă de fulgi de porumb	<ol style="list-style-type: none"> 1. Pune cartofii în coș și prăjește-i 15 minute la 180°C. 2. Agită și împinge cartofii prăjiți în partea dreaptă a coșului cu ajutorul separatorului de tavă. În partea stângă, adăugă 4 bucăți de pește și prăjește încă 12 minute la 180°C, apoi întoarce peștele la jumătatea timpului de gătit. 	
	Compartimentul din dreapta (B)	1,2 kg de cartofi congelați		
Opțiunea de masă 3: friptură de vită cu legume și cartofi	Compartimentul din stânga (A)	Carne de vită mare, prăjită, de cel puțin 900 g	<ol style="list-style-type: none"> 1. Adăugă carnea de vită prăjită în stânga, adăugă și sonda de temperatură și programează aparatul la 50/55/60°C. 2. La jumătatea timpului de preparare, adăugă legumele jos și cartofii în dreapta până când temperatura este atinsă. 	
	Compartimentul din dreapta (B)	800 g cartofi wedges		
	Compartimentul de jos (C)	700 g legume tocate		
Cartofi prăjiți și gustări	Compartimentul din stânga (A)	4 nuggets de pui.	<ol style="list-style-type: none"> 1. Prăjește totul la 180°C până când mâncarea devine crocantă. 	
	Compartimentul din dreapta (B)	800 g cuburi de cartofi		
	Compartimentul de jos (C)	Gustări vegetariene - ciuperci cu crustă crocantă		
Timpul unei gustări vegetariene asiatice	Compartimentul din stânga (A)	400 g bucăți de crab marinate de 2 cm	<ol style="list-style-type: none"> 1. Adăugă bucățile de crab în stânga și pachetele de primăvară și frigăruiile de tofu în dreapta și lasă-le la prăjit timp de 12 minute la 180°C. 2. Adăugă biscuiții jos și prăjește totul timp de 4 minute la 180°C până când mâncarea devine crocantă. 	
	Compartimentul din dreapta (B)	500 g rulouri de primăvară vegetariene + 4 frigărui de tofu vegetariene		
	Compartimentul de jos (C)	100 g biscuiți udang		



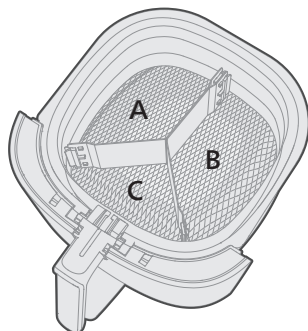

Pokrm	Priestor	Zloženie		
Raňajky	Ľavé (A)	5 vajíčok	8 – 9 min	160°C
	Pravé (B)	5 kusov chleba alebo 5 croissantov		
	Nízka (C)	4 plátky toastu		
Anglické raňajky	Ľavé (A)	4 malé klobásky + 4 kusy raňajkového sadla	10 – 11 min	180°C
	Pravé (B)	4 vaječné suflé v muffinových košíčkoch		
	Nízka (C)	4 krajce toastového chleba		
Možnosť výberu jedla 1: 1 kuracie prsia/ malé zemiaky/ zeleninová zmes	Ľavé (A)	4 malé kuracie prsia, bio	22 – 25 min, 180°C	Voliteľné: použite teplotnú sondu a nastavte ju na 73°C, a jedlo sa tak pripraví naraz a bez problémov.
	Pravé (B)	900 g nasekanej zeleniny nakrájanej na 1,5 cm zmiešaná s 1 polievkovou lyžicou oleja		
	Nízka (C)	800 g malých šúpaných zemiakov zmiešaných s 1 polievkovou lyžicou oleja		
Možnosť výberu jedla 2: bravčová panenka/ pečené zemiaky/ zeleninová zmes	Ľavé (A)	2 bravčové panenky marinované a rozrezané na polovicu na 4 rovnaké kusy	1. Zemiaky sa pečú v šupke 12 minút pri 180°C. 2. Pridajte zeleninu do nízkej časti a sviečkovicu do ľavej časti a smažte spolu 15 minút pri 180°C, zeleninu počas pečenia raz premiešajte.	
	Pravé (B)	4 múčnaté zemiaky strednej veľkosti		
	Nízka (C)	800 g zeleninovej zmesi nakrájajte na 1,5 cm a zmiešajte s 1 polievkovou lyžicou oleja		



Pokrm	Priestor	Zloženie		
Ryby a hranolky	Ľavé (A)	4 kúsky ryby s kukuričnou krustou	1. Hranolky vložte do košíka a smažte 15 minút pri teplote 180°C. 2. Hranolky potrate a posuňte na pravú stranu košíka pomocou rozdeľovača panvice. Na ľavú stranu vložte 4 kúsky ryby a smažte 12 minút pri teplote 180°C. V polovici doby pečenia ryby otočte.	
	Pravé (B)	1,2 kg mrazených hranolkov		
Možnosť výberu jedla 3: pečené hovädzie mäso so zeleninou a zemiakmi	Ľavé (A)	Veľká hovädzia roštenka aspoň 900 g	1. Do ľavej časti vložte hovädziu roštenku, priložte teplotnú sondu a naprogramujte na 50/55/60°C. 2. V polovici doby pečenia pridajte zeleninu do nízkej časti a zemiaky do pravej časti, kým sa nedosiahne požadovaná teplota.	
	Pravé (B)	800 g zemiakových plátkov		
	Nízka (C)	700 g nasekanej zeleniny		
Hranolky a ľahké jedlo	Ľavé (A)	4 kuracie nugety.	1. Všetko spolu smažte pri teplote 180°C, kým jedlo nebude chrumkavé.	
	Pravé (B)	800 g zemiakových kociek		
	Nízka (C)	Vegetariánske ľahké jedlo – huby s chrumkavou kôrkou		
Čas na vegetariánske ázijské občerstvenie	Ľavé (A)	400 g marinovaných krabov, kúsky 2 cm	1. Do ľavej misky vložte krabie kúsky, do pravej jarné závitky a tofu špízy a smažte 12 minút pri 180°C. 2. Do nízkej misky pridajte sušienky a smažte spolu 4 minúty pri teplote 180°C, kým jedlo nebude chrumkavé.	
	Pravé (B)	500 g vegetariánskych jarných závitkov + 4 vegetariánske tofu špízy		
	Nízka (C)	100 g kreky udang		



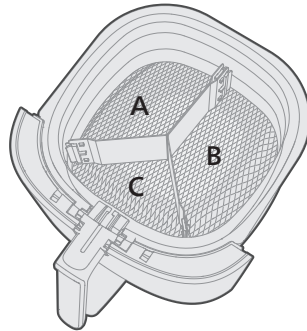

Jedi	Predelek	Sestavine		
Zajtrk	Levi (A)	5 jajc	8–9 min	160°C
	Desni (B)	5 kosov kruha ali 5 rogljičkov		
	Spodnji (C)	4 rezine toasta		
Angleški zajtrk	Levi (A)	4 klobasice + 4 kosi svinjske masti	10–11 min	180°C
	Desni (B)	4 jajčni sufleji v modelčkih za mafine		
	Spodnji (C)	4 rezine toasta		
1. različica obroka: 1 piščančja prsa/ majhni gomolji krompirja/ mešana zelenjava	Levi (A)	4 majhna bio piščančja prsa	22–25 min, 180°C Po želji: uporabite živilski termometer in nastavite na 73°C za enostavno pripravo celega obroka istočasno.	
	Desni (B)	900 g zelenjave, nasekljane na 1,5 cm kose, zmešane z 1 žlico olja		
	Spodnji (C)	800 g majhnih, olupljenih gomoljev krompirja, zmešanih z 1 žlico olja		
2. različica obroka: svinjska ledvena pečenka/ pečen krompir/ mešana zelenjava	Levi (A)	2 kosa mesa za svinjsko ledveno pečenko, marinirana in prerezana na pol, na 4 enake kose	1. Neolupljen krompir pecite 12 minut pri 180°C. 2. Dodajte zelenjavo v spodnji predelek in ledveno pečenko v levi predelek ter pecite skupaj 15 minut pri 180°C. Med peko enkrat premešajte zelenjavo.	
	Desni (B)	4 srednje veliki gomolji mokastega krompirja		
	Spodnji (C)	800 g mešane zelenjave, narezane na 1,5 cm in zmešane z 1 žlico olja		
Riba s krompirčkom	Levi (A)	4 kosi ribe s hrustljivo skorjo	1. Krompirček dajte v košaro in pecite 15 minut pri 180°C. 2. Krompirček pretresite in z razdelilnikom košare potisnite na desno stran košare. V levi predelek dajte 4 kose ribe in pecite 12 minut pri 180°C. Na polovici peke obrnite ribo.	
	Desni (B)	1,2 kg zamrznjenega krompirčka		



Jedi	Predelek	Sestavine		
3. različica obroka: goveja pečenko z zelenjavo in krompirjem	Levi (A)	Velik kos govedine za pečenko iz 900 g	1. Dajte govedino za pečenko v levi predelek, dodajte živilski termometer in nastavite na 50/55/60°C. 2. Na polovici peke dodajte zelenjavo v spodnji predelek in krompir v desni predelek ter pecite, dokler ni dosežena zelena temperatura.	
	Desni (B)	800 g krompirja v kosih		
	Spodnji (C)	700 g nasekljane zelenjave		
Krompirček in prigrizki	Levi (A)	4 piščančji kroketi	1. Pecite vse skupaj pri 180°C, dokler ni hrustljivo zapečeno.	
	Desni (B)	800 g krompirja, narezanega na kocke		
	Spodnji (C)	Vegetarijanski prigrizek: hrustljave gobe		
Vegetarijanski azijski prigrizek	Levi (A)	400 g mariniranih rakovih kroglic premera 2 cm	1. Dajte rakove kroglice v levi predelek ter spomladanske zavitke in nabadala s tofujem v desni predelek. Pecite 12 minut pri 180°C. 2. Dajte krekerje v spodnji predelek in pecite skupaj 4 minute pri 180°C, dokler ni hrustljivo zapečeno.	
	Desni (B)	500 g vegetarijanskih spomladanskih zavitkov + 4 vegetarijanska nabadala s tofujem		
	Spodnji (C)	100 g krekerjev iz kozic		



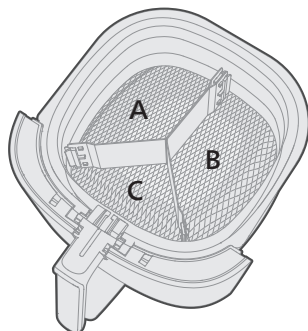

Gatimet	Ndarja	Përbërësit		
Mëngjes	Majtas (A)	5 vezë	8–9 min	160°C
	Djathtas (B)	5 feta buke ose 5 brioshë		
	I ulët (C)	4 feta për thekje		
Mëngjes anglez	Majtas (A)	4 salsiçe të vogla + 4 copë sallo për mëngjes	10–11 min	180°C
	Djathtas (B)	4 sufle veze në kupa kekësh të vegjël		
	I ulët (C)	4 feta bukë për thekje		
Opsioni i vaktit 1: 1 gjoks pule / patate të vogla / miks perimesh	Majtas (A)	4 gjokse pulash të vogla bio	22–25 min, 180°C	Opsionale: përdorni termometrin dhe caktojini në 73°C për ta bërë vaktin me të parën pa telashe.
	Djathtas (B)	900 g perime të copëtuara në 1,5cm përzier me 1 lugë gjelle vaj		
	I ulët (C)	800 g patate të vogla dhe të qëruara, përzier me 1 lugë gjelle vaj		
Opsioni i vaktit 2: Filetë derri / patate furre / miks perimesh	Majtas (A)	2 fileta derri të marinuar dhe të prera përgjysmë në 4 pjesë të barabarta	1. Piqini patatet me lëkurë për 12 minuta në 180°C. 2. Shtoni perimet poshtë dhe filetën majtas dhe skuqini së bashku për 15 minuta në 180°C dhe trazojini perimet një herë gjatë gatimit.	
	Djathtas (B)	4 patate miellëse madhësie mesatare		
	I ulët (C)	800 g miks perimesh prerë në 1,5 cm dhe përzier me 1 lugë gjelle vaj		
Peshk me patate të skuqura	Majtas (A)	4 copë peshku me kore misri	1. Vendosini patatet e prera në shportë dhe skuqini për 15 minuta në 180°C. 2. Shkundini dhe kalojini patatet e skuqura në anën e djathtë të koshit me ndarësin e tiganit. Shtoni në anën e majtë 4 copa peshku dhe skuqini për 12 minuta në 180°C, kthejeni peshkun në gjysmë të kohës së gatimit.	
	Djathtas (B)	1,2 kg patate të ngrira për skuqje		

Gatimet	Ndarja	Përbërësit		
Opsioni i vaktit 3: Rosto me perime dhe patate	Majtas (A)	Rosto viçi nga 900 g	<ol style="list-style-type: none"> Shtoni roston e viçit në të majtë, shtoni termometrin dhe programojeni në 50/55/60°C. Në gjysmë të kohës së gatimit, shtoni perimet poshtë dhe patatet djathtas derisa të arrihet temperatura. 	
	Djathtas (B)	800 g copa të mëdha patatesh		
	I ulët (C)	700 g perime të prera		
Patate të skuqura dhe ushqime të vogla	Majtas (A)	4 kroketa pule.	<ol style="list-style-type: none"> Skuqini të gjitha së bashku në 180°C derisa ushqimi të bëhet kroatant. 	
	Djathtas (B)	800 g kubikë patatesh		
	I ulët (C)	Ushqime vegjetariane - kërpudha me kore krokante		
Koha e ushqimeve vegjetariane aziatike	Majtas (A)	400 g copëza gaforresh të marinuara 2 cm	<ol style="list-style-type: none"> Shtoni copëzat e gaforreve majtas dhe roletë me perime, dhe hejet me tofu djathtas, dhe skuqini për 12 minuta në 180°C. Shtoni feta Cracker poshtë dhe skuqini së bashku për 4 minuta në 180°C derisa ushqimi të bëhet kroatant. 	
	Djathtas (B)	500 g roleta me perime vegjetariane + 4 heje me tofu vegjetariane		
	I ulët (C)	100 g feta Udang Crackers		



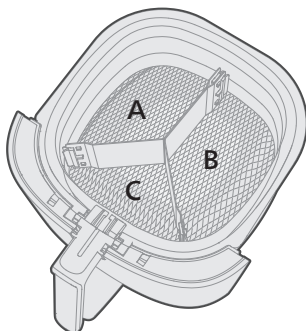

Jela	Odeljak	Sastojci		
Doručak	Levo (A)	5 jaja	8–9 min	160° C
	Desno (B)	5 komada hleba ili 5 kroasana		
	Dole (C)	4 kriške tosta		
Engleski doručak	Levo (A)	4 male kobasice + 4 komada masti za doručak	10–11 min	180° C
	Desno (B)	4 suflea od jaja u čašama za mafine		
	Dole (C)	4 kriške tosta		
Opcija za obrok 1: 1 pileća prsa / mali krompiri / mešavina povrća	Levo (A)	4 mala komada organskih pilećih prsa	22–25 min, 180° C	Opciono: koristite temperaturnu sondu i podesite je na 73° C da biste obrok napravili odjednom, bez muke.
	Desno (B)	900 g povrća iseckanog na komade od 1,5 cm pomešano sa 1 kašikom ulja		
	Dole (C)	800 g malih, oljuštenih krompira pomešanih sa 1 kašikom ulja		
Opcija za obrok 2: Svinjski biftek / pečeni krompiri / mešavina povrća	Levo (A)	2 svinjska bifteka marinirana i isečena na pola, na 4 jednaka komada	1. Pecite krompire sa korom 12 minuta na 180° C.	2. Dodajte povrće sole i biftek levo i pecite zajedno 15 minuta na 180° C, uz jedno mešanje povrća tokom pripreme.
	Desno (B)	4 prospita krompira srednje veličine		
	Dole (C)	800 g mešanog povrća isečenog na komade od 1,5 cm i pomešano sa 1 kašikom ulja		
Riba i pomfrit	Levo (A)	4 komada pohovane ribe	1. Stavite pomfrit u korpu i pržite 15 minuta na 180° C.	2. Protresite i pomerite krompir na desnu stranu korpe pomoću graničnika. Sa leve strane dodajte 4 komada ribe, pržite 12 minuta na 180° C i okrenite ribu na pola vremena pripreme.
	Desno (B)	1,2 kg smrznutog pomfrita		

Jela	Odeljak	Sastojci		
Opcija za obrok 3: Govede pečenje sa povrćem i krompirom	Levo (A)	Veliki komad govedine od 900 g	<ol style="list-style-type: none"> 1. Dodajte govedinu sa leve strane i dodajte temperaturnu sondu sa programom 50/55/60°C. 2. Na pola vremena pripreme dodajte povrće dole i krompir sa desne strane dok se ne postigne temperatura. 	
	Desno (B)	800 g režnjeva krompira		
	Dole (C)	700 g iseckanog povrća		
Pomfrit i grickalice	Levo (A)	4 pileća medaljona.	<ol style="list-style-type: none"> 1. Pržite sve zajedno na 180°C dok hrana ne postane hrskava. 	
	Desno (B)	800 g kockica krompira		
	Dole (C)	Vegetarijanske grickalice, pečurke sa hrskavom koricom		
Vegetarijanske azijske grickalice	Levo (A)	400 g mariniranih zalogaja od krabe, 2 cm	<ol style="list-style-type: none"> 1. Dodajte zalogaje od krabe levo, a prolećne rolnice i tofu različite desno, pa pržite 12 minuta na 180°C. 2. Dodajte krekeri dole i pržite zajedno 4 minuta na 180°C dok hrana ne postane hrskava. 	
	Desno (B)	500 g vegetarijanskih prolećnih rolnica + 4 vegetarijanska tofu različija		
	Dole (C)	100 g udang krekeri		





Rätter	Fack	Ingredienser		
Frukost	Vänster (A)	5 ägg	8–9 minuter	160°C
	Höger (B)	5 brödskivor eller 5 croissanter		
	Låg (C)	4 skivor rostbröd		
Engelsk frukost	Vänster (A)	4 små korvar + 4 skivor bacon	10–11 minuter	180°C
	Höger (B)	4 äggsuffléer i muffinsformar		
	Låg (C)	4 skivor rostbröd		
Måltidsalternativ 1: 1 kycklingbröst/ små potatisar/ blandade grönsaker	Vänster (A)	4 små ekologiska kycklingbröst	22–25 minuter, 180°C	Valfritt: Använd stektermometern och ställ in den på 73°C för att smidigt laga allt på en gång.
	Höger (B)	900 g grönsaker skurna i 1,5 cm stora bitar blandade med 1 matsked olja		
	Låg (C)	800 g små, skalade potatisar blandade med 1 matsked olja		
Måltidsalternativ 2: Fläskfilé/bakad potatis/ blandade grönsaker	Vänster (A)	2 marinerade fläskfiléer som skurits i 4 lika stora bitar	1. Baka potatisen med skalet på i 12 minuter i 180°C. 2. Tillsätt grönsakerna i det nedre facket (Låg) och fläskfiléerna i vänster fack och stek tillsammans i 15 minuter i 180°C och rör om grönsakerna en gång under tillagningen.	
	Höger (B)	4 medelstora mjöliga potatisar		
	Låg (C)	800 g blandade grönsaker skurna i 1,5 cm stora bitar och blandade med 1 matsked olja		

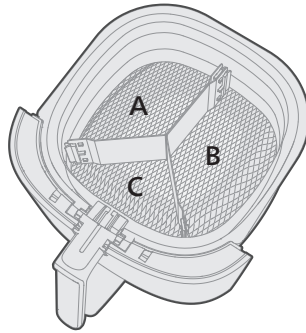

Rätter	Fack	Ingredienser		
Fish & Chips	Vänster (A)	4 fiskbitar med cornflakespanering	1. Lägg pommes fritesen i korgen och fritera i 15 minuter i 180°C. 2. Skaka pommes fritesen och placera dem i höger fack i korgen med hjälp av pannavdelaren. Lägg de 4 fiskbitarna i vänster fack i korgen och fritera i 12 minuter i 180°C. Vänd fisken halvvägs.	
	Höger (B)	1,2 kg frysta pommes frites		
Måltidsalternativ 3: Oxstek med grönsaker och potatis	Vänster (A)	Stor oxstek på 900 g	1. Lägg oxsteken i vänster fack och stick in stekermometern och ställ in den på 50/55/60°C. 2. Tillsätt grönsakerna i det nedre facket (Låg) och potatisen i höger fack efter halva tiden till dess att temperaturen uppnås.	
	Höger (B)	800 g klyftpotatis		
	Låg (C)	700 g grönsaker skurna i bitar		
Pommes frites och snacks	Vänster (A)	4 kycklingnuggets.	1. Fritera allt tillsammans i 180°C till dess att maten är krispig.	
	Höger (B)	800 g potatiskuber		
	Låg (C)	Vegetariskt svampsnack med krispig panering		
Vegetariska asiatiska snacks	Vänster (A)	400 g marinerade krabbitar på 2 cm	1. Lägg krabbitarna i vänster fack och vårrullarna och tofuspetten i höger fack och fritera i 12 minuter i 180°C. 2. Tillsätt räkchipsen i det nedre facket (Låg) och fritera tillsammans i 4 minuter i 180°C till dess att maten är krispig.	
	Höger (B)	500 g vegetariska vårrullar + 4 vegetariska tofuspett		
	Låg (C)	100 g räkchips		



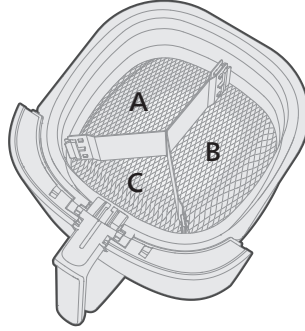

อาหาร	ช่องเก็บ	ส่วนผสม		
อาหารเซ้า	ด้านบน (A)	ไข่ 5 ฟอง	8-9 นาที	160°C
	ด้านขวา (B)	ขนมปัง 5 ชิ้นหรือครัวซองต์ 5 ชิ้น		
	ต่ำ (C)	ขนมปังปัง 4 ชิ้น		
อาหารเซ้าแบบอังกฤษ	ด้านบน (A)	ไส้กรอกเล็ก 4 ชิ้น + 4 ชิ้น น้ำมันหมู	10-11 นาที	180°C
	ด้านขวา (B)	ไข่ซูเฟลในถ้วยมีฟัพ 4 ถ้วย		
	ต่ำ (C)	ขนมปังปัง 4 ชิ้น		
ตัวเลือกอาหาร 1: ออกไก่ 1 ชิ้น / มันฝรั่งลูกเล็ก / ผักรวม	ด้านบน (A)	อกไก่ขนาดเล็ก 4 ชิ้น	22-25 นาที, 180°C	อุปกรณ์เสริม: ใช้หัววัดอุณหภูมิและตั้งอุณหภูมิไว้ที่ 73°C เพื่อทำอาหารในคราวเดียวโดยไม่ยุ่งยาก
	ด้านขวา (B)	ผักสับ 900 ก. หั่นเป็นชิ้นขนาด 1.5 ซม. ผสมกับน้ำมัน 1 ช้อนโต๊ะ		
	ต่ำ (C)	มันฝรั่งปอกเปลือกขนาดเล็ก 800 ก. ผสมกับน้ำมัน 1 ช้อนโต๊ะ		
ตัวเลือกอาหาร 2: เนื้อสันในหมู / มันฝรั่งอบ / ผักรวม	ด้านบน (A)	เนื้อสันในหมู 2 ชิ้นหมักและผ่าครึ่ง เป็น 4 ชิ้นเท่าๆ กัน	1. อบมันฝรั่งทิ้งเปลือกเป็นเวลา 12 นาทีที่อุณหภูมิ 180°C	2. ใส่ผักด้านล่างและเนื้อสันในด้านบน แล้วทอดด้วยกันเป็นเวลา 15 นาทีที่ 180°C และคนผักหนึ่งครั้งระหว่างการปรุงอาหาร
	ด้านขวา (B)	มันฝรั่งขนาดกลาง 4 หัว		
	ต่ำ (C)	ผักรวม 800 ก. หั่นเป็นชิ้นขนาด 1.5 ซม. ผสมกับน้ำมัน 1 ช้อนโต๊ะ		

อาหาร	ช่องเก็บ	ส่วนผสม		
พีชแอนดชีป	ด้านซ้าย (A)	ปลา 4 ชั้นซุบคอร์นเฟลก	1. วางมันฝรั่งลงในตะกร้า แล้วทอดเป็นเวลา 15 นาทีที่อุณหภูมิ 180°C 2. เขย่าและเลื่อนมันฝรั่งทอดไปทางด้านขวาของตะกร้าโดยใช้ที่แบ่งกระดาษ ใส่ปลา 4 ชั้นทางด้านซ้ายแล้วทอดเป็นเวลา 12 นาทีที่อุณหภูมิ 180°C แล้วกลับด้านของปลาระหว่างปรุงอาหาร	
	ด้านขวา (B)	มันฝรั่งแช่แข็ง 1.2 กก.		
ตัวเลือกอาหาร 3: เนื้อย่างพร้อมผักและมันฝรั่ง	ด้านซ้าย (A)	เนื้อย่างชิ้นใหญ่เริ่มต้นที่ 900 ก.	1. ใส่เนื้อย่างทางด้านซ้ายและสับหัววัดอุณหภูมิและตั้งโปรแกรมไว้ที่ 50/55/60°C 2. เมื่อผ่านไปได้ครึ่งทางของเวลาปรุงอาหาร ให้ใส่ผักลงในด้านล่างและมันฝรั่งในด้านล่างจนกระทั่งถึงอุณหภูมิ	
	ด้านขวา (B)	มันฝรั่งตัดเปลือก 800 ก.		
	ต่ำ (C)	ผักสับ 700 ก.		
มันฝรั่งทอดและของว่าง	ด้านซ้าย (A)	มักเก็ตไก่ 4 ชั้น	1. ทอดทุกอย่างด้วยกันที่อุณหภูมิ 180°C จนกระทั่งอาหารกรอบ	
	ด้านขวา (B)	มันฝรั่งหั่นเต๋า 800 ก.		
	ต่ำ (C)	ของว่างมังสวิรัตกับเห็ดซุบแปงทอด		
ของว่างมังสวิรัตแบบเอเชีย	ด้านซ้าย (A)	บิสกิตปูหมัก 400 ก. ขนาด 2 ซม.	1. ใส่บิสกิตปูทางด้านซ้ายปอเปียะและเต้าหู้สียบไม้ทางด้านขวา แล้วทอดที่อุณหภูมิ 180°C เป็นเวลา 12 นาที 2. ใส่แครกเกอร์ด้านล่างแล้วทอดด้วยกันเป็นเวลา 4 นาทีที่อุณหภูมิ 180°C จนกระทั่งอาหารกรอบ	
	ด้านขวา (B)	ปอเปียะมังสวิรัต 500 ก. + เต้าหู้มังสวิรัตสียบไม้ 4 ชั้น		
	ต่ำ (C)	แครกเกอร์อูตัง 100 ก.		



Yemekler	Bölme	Malzemeler		
Kahvaltı	Sol (A)	5 yumurta	8–9 dk	160°C
	Sağ (B)	5 parça ekmek veya 5 kruvasan		
	Alt (C)	4 dilim ekmek		
İngiliz kahvaltısı	Sol (A)	4 küçük sosis + 4 parça kahvaltılık kuyruk yağı	10–11 dk	180°C
	Sağ (B)	Muffin kaplarında 4 yumurta suflesi		
	Alt (C)	4 dilim tost ekmeği		
Yemek seçeneği 1: 1 tavuk göğsü / küçük patates / sebze karışımı	Sol (A)	4 küçük organik tavuk göğsü	22–25 dk, 180°C	İsteğe bağlı: Yemeği tek seferde zahmetsizce yapmak için sıcaklık probunu kullanın ve 73°C'ye ayarlayın.
	Sağ (B)	1,5 cm kalınlığında kesilip doğranmış ve 1 yemek kaşığı yağ ile karıştırılmış 900 g sebze		
	Alt (C)	1 yemek kaşığı yağ ile karıştırılmış 800 g küçük, soyulmuş patates		
Yemek seçeneği 2: 2 dana bonfile / fırında patates / sebze karışımı	Sol (A)	Marine edilip 4 eşit parçaya bölünmüş 2 dana bonfile	1. Patatesleri kabuklarını soymadan 180°C'de 12 dakika boyunca pişirin. 2. Sebzeleri Alt bölmeye bonfileyi Sol bölmeye ekleyip birlikte 180°C'de 15 dakika boyunca kızartın ve pişirme sırasında sebzeleri bir kez karıştırın.	
	Sağ (B)	4 adet orta boy kızartmalık patates		
	Alt (C)	1,5 cm kalınlığında kesilip 1 yemek kaşığı yağ eklenmiş 800 g sebze karışımı		
Balık ve Patates	Sol (A)	Mısır gevreğiyle kaplanmış 4 parça balık	1. Patatesleri sepete koyun ve 180°C'de 15 dakika kızartın. 2. Patatesleri sallayın ve tava ayırıcıyı kullanarak sepetin sağ tarafına kaydırın. Sol bölmeye 4 parça balık ekleyip 180°C'de 12 dakika kızartın ve pişirme süresinin yarısına gelince balıkları çevirin.	
	Sağ (B)	1,2 kg dondurulmuş patates		

Yemekler	Bölme	Malzemeler		
Yemek seçeneği 3: sebzeli ve patatesli rozbif	Sol (A)	900 g büyük rozbif		
	Sağ (B)	800 g elma dilim patates		
	Alt (C)	700 g doğranmış sebze		
Kızartmalar ve Atıştırmalıklar	Sol (A)	4 tavuk nugget.		
	Sağ (B)	800 g küp doğranmış patates		
	Alt (C)	Vejetaryen atıştırmalıklar - dışı çtır mantarlar		
Asya mutfağından vejetaryen atıştırmalık zamanı	Sol (A)	400 g marine edilmiş 2 cm kalınlığında doğranmış yengeç eti		
	Sağ (B)	500 g vejetaryen çin böreği + 4 vejetaryen tofu şiş		
	Alt (C)	100 g karides cipsi		

1. Sol bölmeye rozbifi ekleyin, sıcaklık probunu ekleyip 50/55/60°C'ye programlayın.
2. Pişirme süresinin yarısında, sıcaklığa ulaşılan kadar Alt bölmeye sebzeleri, Sağ bölmeye patatesleri ekleyin.

1. Yiyeceğiniz çtır çtır olana kadar her şeyi 180°C'de kızartın.

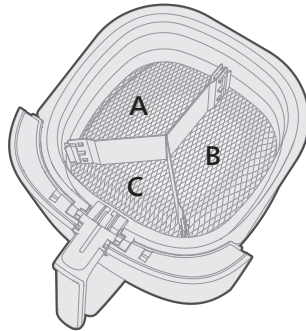

1. Sol bölmeye yengeç etlerini, Sağ bölmeye çin böreklerini ve tofu şişleri ekleyin ve 180°C'de 12 dakika kızartın.
2. Cipsleri Alt bölmeye ekleyin ve yiyeceğiniz çtır çtır olana kadar 180°C'de 4 dakika boyunca birlikte kızartın.



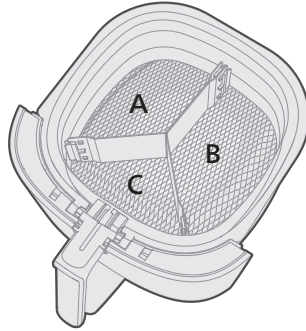

Страви	Відділення	Інгредієнти		
Сніданок	Ліве (А)	5 яєць	8–9 хв	160°C
	Праве (В)	5 хлібців або 5 круасанів		
	Нижнє (С)	4 скибки грінок		
Англійський сніданок	Ліве (А)	4 малі ковбаски + 4 шматки сала на сніданок	10–11 хв	180°C
	Праве (В)	4 яєчні суфле в формах для мафінів		
	Нижнє (С)	4 скибки хліба для грінок		
Варіант страви № 1: 1 куряча грудинка / малі картоплини / мікс овочів	Ліве (А)	4 невеликі органічні курячі грудинки	22–25 хв, 180°C	Додатково: використовуйте щуп температури та встановіть 73°C для приготування страви за один раз без зайвих зусиль.
	Праве (В)	900 г подрібнених овочів, порізаних кубиками по 1,5 см, змішаних із 1 стол. ложкою олії		
	Нижнє (С)	800 г невеликих очищених картоплин, змішаних із 1 стол. ложкою олії		
Варіант страви № 2: свиняча вирізка / печена картопля / мікс овочів	Ліве (А)	2 замариновані свинячі вирізки, порізані навпіл на 4 однакові шматки	1. Запікайте картоплю в мундирах протягом 12 хвилин за температури 180°C. 2. Додайте овочі в нижнє відділення, а вирізку – в ліве, і смажте разом протягом 15 хвилин за температури 180°C, перемішуючи овочі один раз під час приготування.	
	Праве (В)	4 картоплини середнього розміру (розсипчастого сорту)		
	Нижнє (С)	800 г міксу овочів, порізаних кубиками по 1,5 см і змішаних з 1 стол. ложкою олії		

Страви	Відділення	Інгредієнти		
Риба й чипси	Ліве (А)	4 шматки риби з кукурудзяною скоринкою	<ol style="list-style-type: none"> 1. Покладіть картоплю-фрі в кошик і смажте протягом 15 хвилин за температури 180°C. 2. Струсіть і пересуньте картоплю на праву сторону кошика за допомогою розділювача чаші. Додайте на ліву сторону 4 шматки риби і смажте її протягом 12 хвилин за температури 180°C, час від часу перевертаючи рибу протягом приготування. 	
	Праве (В)	1,2 кг замороженої картоплі-фрі		
Варіант страви № 3: ростбіф з овочами й картоплею	Ліве (А)	Великий шматок яловичини від 900 г	<ol style="list-style-type: none"> 1. Додайте яловичину на ліву сторону, встановіть шуп температури й запрограмуйте 50/55/60°C. 2. У процесі приготування додайте овочі в нижнє відділення, а картоплю – у праве, поки не буде досягнуто потрібної температури. 	
	Праве (В)	800 г картоплі дольками		
	Нижнє (С)	700 г нарізаних овочів		
Картопля-фрі й закуски	Ліве (А)	4 курячі нагетси	<ol style="list-style-type: none"> 1. Смажте все разом за температури 180°C до хрусткості. 	
	Праве (В)	800 г картоплі кубиками		
	Нижнє (С)	Вегетаріанські закуски: гриби із хрусткою скоринкою		
Азійські закуски по-вегетаріанськи	Ліве (А)	400 г маринованих крабів шматками по 2 см	<ol style="list-style-type: none"> 1. Додайте шматки крабів на ліву сторону, а завиванці та шпажки з тофу – на праву, і смажте протягом 12 хвилин за температури 180°C. 2. Додайте крекери в нижнє відділення і смажте разом протягом 4 хвилин за температури 180°C до хрусткості. 	
	Праве (В)	500 г завиванців з овочами + 4 шпажки з вегетаріанським тофу		
	Нижнє (С)	100 г крекерів "udang"		



Món ăn	Ngăn	Nguyên liệu		
Bữa sáng	Trái (A)	5 quả trứng	8–9 phút	160°C
	Phải (B)	5 miếng bánh mì hoặc 5 bánh sừng bò		
	Dưới (C)	4 lát bánh mì nướng		
Bữa sáng kiểu Anh	Trái (A)	4 xúc xích nhỏ + 4 miếng mỡ lợn ăn sáng	10–11 phút	180°C
	Phải (B)	4 bánh souffle trứng trong cốc muffin		
	Dưới (C)	4 lát bánh mì nướng		
Lựa chọn bữa ăn 1: 1 ức gà / khoai tây nhỏ / rau trộn	Trái (A)	4 ức gà hữu cơ nhỏ	22–25 phút, 180°C	Tùy chọn: sử dụng dầu dò nhiệt độ và đặt ở mức 73°C để nhanh chóng chế biến bữa ăn chỉ trong một lần.
	Phải (B)	900 g rau củ cắt khúc 1,5cm trộn với 1 muống canh dầu		
	Dưới (C)	800 g khoai tây gọt vỏ nhỏ trộn với 1 muống canh dầu		
Lựa chọn bữa ăn 2: Thịt lợn thăn / khoai tây nướng / rau trộn	Trái (A)	2 thăn lợn ướp và cắt làm đôi thành 4 miếng bằng nhau	1. Nướng khoai tây cả vỏ trong 12 phút ở 180°C. 2. Thêm rau vào ngăn dưới và thịt nạc thăn vào ngăn trái và chiên cùng nhau trong 15 phút ở 180°C và đảo rau một lần trong khi nấu.	
	Phải (B)	4 củ khoai tây bột cỡ vừa		
	Dưới (C)	800 g hỗn hợp rau cắt thành 1,5 cm và trộn với 1 muống canh dầu		
Cá và khoai tây chiên	Trái (A)	4 miếng cá với lớp vỏ bánh bột ngô	1. Cho khoai tây vào giỏ và chiên trong 15 phút ở 180°C. 2. Lắc và trượt khoai tây chiên sang bên phải giỏ bằng vách ngăn nồi chiên. Thêm vào bên trái 4 miếng cá và chiên trong 12 phút ở 180°C và lật cá khi nấu được nửa thời gian.	
	Phải (B)	1,2 kg khoai tây chiên đông lạnh		

Món ăn	Ngăn	Nguyên liệu		
Lựa chọn bữa ăn 3: Thịt bò nướng với rau và khoai tây	Trái (A)	Thịt bò nướng lớn từ 900 g	<ol style="list-style-type: none"> 1. Thêm thịt bò nướng vào ngăn trái và thêm dầu dò nhiệt độ và lập trình ở mức 50/55/60°C. 2. Khi nấu được nửa thời gian, hãy thêm rau vào ngăn dưới và khoai tây vào ngăn phải cho đến khi đạt đến nhiệt độ. 	
	Phải (B)	800 g khoai tây múi cau		
	Dưới (C)	700 g rau củ cắt nhỏ		
Khoai tây chiên và đồ ăn nhẹ	Trái (A)	4 miếng gà viên.	<ol style="list-style-type: none"> 1. Chiên mọi thứ cùng nhau ở nhiệt độ 180°C cho đến khi thức ăn giòn. 	
	Phải (B)	800 g khoai tây viên		
	Dưới (C)	Món ăn vật chay - nấm chiên giòn		
Bữa ăn nhẹ châu Á chay	Trái (A)	400 g miếng cua ướp 2cm	<ol style="list-style-type: none"> 1. Thêm miếng cua vào ngăn trái, chả giò và đậu hũ xiên vào ngăn phải, chiên trong 12 phút ở nhiệt độ 180°C. 2. Thêm bánh phồng tôm vào ngăn dưới và chiên cùng nhau trong 4 phút ở 180°C cho đến khi thức ăn giòn. 	
	Phải (B)	500 g chả giò chay + 4 xiên đậu hũ chay		
	Dưới (C)	100 g bánh phồng tôm		

简体中文

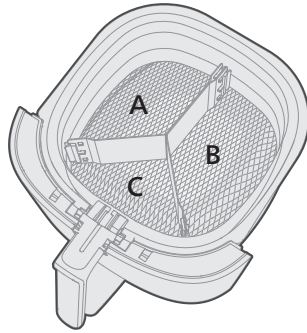

菜肴	分隔区	原料		
早餐	左侧 (A)	5 个鸡蛋	8-9 分钟	160°C
	右侧 (B)	5 片面包或 5 个可颂		
	下方 (C)	4 片吐司		
英式早餐	左侧 (A)	4 根小香肠 + 4 份早餐猪油	10-11 分钟	180°C
	右侧 (B)	4 份蛋奶酥装在玛芬杯中		
	下方 (C)	4 片吐司面包		
餐食选项 1: 1 块鸡脯/小份土豆/什锦蔬菜	左侧 (A)	4 份小块有机鸡脯	22-25 分钟, 180°C 可选: 使用温度探头, 将温度设置为 73°C, 即可一次性完成烹饪, 轻松无忧。	
	右侧 (B)	900 克切碎成 1.5 厘米长的蔬菜加 1 汤匙油		
	下方 (C)	800 克去皮小土豆加 1 汤匙油		
食材选项 2: 猪里脊肉/烤土豆/什锦蔬菜	左侧 (A)	2 块腌制好的猪里脊肉, 对半切成 4 等份	1. 180°C 下带皮烤土豆 12 分钟。 2. 下方分隔区加入蔬菜, 左侧分隔区加入里脊肉, 在 180°C 下同时煎炸 15 分钟, 烹饪过程中搅拌蔬菜一次。	
	右侧 (B)	4 个中等大小粉质土豆		
	下方 (C)	800 克切碎成 1.5 厘米长的什锦蔬菜加 1 汤匙油		

菜肴	分隔区	原料		
炸鱼和薯条	左侧 (A)	4 块鱼肉配玉米片	<ol style="list-style-type: none"> 1. 将薯条放入炸篮中，180°C 下煎炸 15 分钟。 2. 摇晃炸篮，并使用煎锅分隔器将薯条放到炸篮右侧。左侧分隔区加入 4 块鱼，在 180°C 下煎炸 12 分钟，烹饪中途翻面。 	
	右侧 (B)	1.2 千克冷冻薯条		
食材选项 3: 烤牛肉配蔬菜和土豆	左侧 (A)	900 克大块烤牛肉	<ol style="list-style-type: none"> 1. 在左侧分隔区加入烤牛肉，然后放置温度探头，并将温度设置为 50/55/60°C。 2. 烹饪时间过半时，在下方分隔区加入蔬菜，在右侧分隔区加入土豆，直到达到设定温度。 	
	右侧 (B)	800 克薯角		
	下方 (C)	700 克切碎蔬菜		
炸薯条和点心	左侧 (A)	4 份炸鸡块。	<ol style="list-style-type: none"> 1. 180°C 下将所有食材一同煎至松脆。 	
	右侧 (B)	800 克土豆丁		
	下方 (C)	素食小吃 - 酥炸蘑菇		
亚洲素食主义者的点心时间	左侧 (A)	400 克 2 厘米长腌制蟹柳	<ol style="list-style-type: none"> 1. 左侧分隔区放入蟹柳，右侧分隔区放入春卷和豆腐串，在 180°C 下煎炸 12 分钟。 2. 下方分隔区放入饼干，一同在 180°C 下煎炸 4 分钟，直至食物变松脆。 	
	右侧 (B)	500 克素春卷 + 4 串素豆腐串		
	下方 (C)	100 克虾饼		

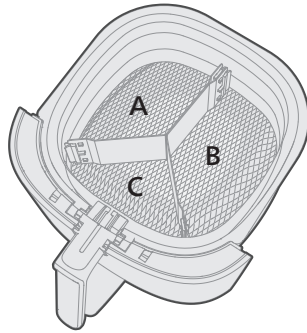

料理	隔層	食材		
早餐	左 (A)	5 顆雞蛋	8-9 分鐘	160°C
	右 (B)	5 塊麵包或 5 個可頌		
	低 (C)	4 片吐司		
英式早餐	左 (A)	4 條小香腸 + 4 塊早餐豬油	10-11 分鐘	180°C
	右 (B)	4 個雞蛋舒芙蕾裝在馬芬烤模中		
	低 (C)	4 片吐司麵包		
餐點選項 1： 1 塊雞胸肉 / 小番茄 / 什錦 蔬菜	左 (A)	4 小塊有機雞胸肉	22-25 分鐘，180°C 可選：使用溫度探針並設定在 73°C 以便一次輕鬆完成餐點。	
	右 (B)	900 公克的切碎蔬菜 (大小為 1.5 公分)，混合 1 大匙油		
	低 (C)	800 公克的小塊去皮馬鈴薯，混合 1 大匙油		
餐點選項 2： 豬里肌肉 / 烤 番茄 / 什錦 蔬菜	左 (A)	2 塊醃過的豬里肌肉，對切成 4 等份	1. 連皮烤馬鈴薯，用 180°C 烤 12 分鐘。 2. 將蔬菜放入低側，將里肌肉放入左側，並用 180°C 炸 15 分鐘，並在烹煮時翻動蔬菜一次。	
	右 (B)	4 塊質地略粉的馬鈴薯 (中等大小)		
	低 (C)	800 公克的什錦蔬菜 (大小為 1.5 公分)，混合 1 大匙油		

料理	隔層	食材		
炸魚薯條	左 (A)	4 塊脆皮魚排		<ol style="list-style-type: none"> 將薯條放入炸籃並用 180°C 炸 15 分鐘。 搖晃薯條並使用炸鍋隔板其滑到炸籃右側。將 4 塊魚排放入左側並用 180°C 炸 12 分鐘，並在烹煮時間過去一半後將魚排翻面。
	右 (B)	1.2 公斤薯條		
餐點 3：烤牛肉佐蔬菜與馬鈴薯	左 (A)	大塊烤牛肉 (900 公克起)		<ol style="list-style-type: none"> 將烤牛肉放入左側並放入溫度探針，然後將程式設定在 50/55/60°C。 烹煮時間過去一半後，將蔬菜放入低側，馬鈴薯放入右側，直到達到溫度。
	右 (B)	800 公克厚切薯條		
	低 (C)	700 公克切碎蔬菜		
薯條和點心	左 (A)	4 塊雞塊。		<ol style="list-style-type: none"> 用 180°C 炸所有食材直到酥脆。
	右 (B)	800 公克馬鈴薯塊		
	低 (C)	素點心脆皮蘑菇		
亞洲素點心時間	左 (A)	400 公克的醃蟹柳 (2 公分)		<ol style="list-style-type: none"> 將蟹柳放入左側，春捲和豆腐串放入右側，然後用 180°C 炸 12 分鐘。 將蝦片放入低側一起炸，用 180°C 炸 4 分鐘，直到食材變酥脆。
	右 (B)	500 公克素春捲 + 4 串素豆腐		
	低 (C)	100 公克蝦片		

		مواد	محفظه	غذا
<p>۱. سبب زمینی‌ها را در سبذ بریزید و ۱۵ دقیقه در دمای ۱۸۰ درجه سانتیگراد سرخ کنید.</p> <p>۲. سبب زمینی‌ها را هم بزنید و با تقسیم‌کننده قابل‌مسه به سمت راست قابل‌مسه برانید. در سمت چپ، ۳ تکه ماهی را اضافه کنید و ۱۲ دقیقه در دمای ۱۸۰ درجه سانتیگراد سرخ کنید و در حین پخت، یک مرتبه ماهی را برگردانید.</p>		۴ تکه ماهی با آرد کورن‌فلکس	چپ (A)	ماهی و چیپس
		۱,۲ گرم خلال سبب زمینی یخ زده	راست (B)	
<p>۱. رست بیف را در سمت چپ بگذارید و دماسنج را اضافه کنید و روی برنامه C°۶۰/۵۵/۵۰ قرار دهید.</p> <p>۲. در طول پخت، یک مرتبه برگردانید و سبزیجات را در قسمت پایین و سبب زمینی‌ها را در سمت راست بگذارید تا وقتی به دمای مورد نظر برسد.</p>		۹۰۰ گرم رست بیف بزرگ	چپ (A)	گزینه غذای ۳: رست بیف با سبزیجات و سبب زمینی
		۸۰۰ گرم وچ سبب زمینی	راست (B)	
		۷۰۰ گرم سبزیجات خرد شده	پایین (C)	
<p>۱. با هم در دمای ۱۸۰ درجه سانتیگراد سرخ کنید تا وقتی غذا ترد و کریسپی شود.</p>		۴ ناگت مرغ.	چپ (A)	سبب زمینی سرخ‌کرده و اسنک
		۸۰۰ گرم سبب زمینی قطعه قطعه شده	راست (B)	
		اسنک قارچ با آرد سوخاری	پایین (C)	
<p>۱. تکه‌های خرچنگ و اسپرینگ رول و سیخ‌های توفو را در سمت راست بریزید و ۱۲ دقیقه در دمای ۱۸۰ درجه سانتیگراد سرخ کنید.</p> <p>۲. کرکرها را در قسمت پایین بریزید و ۴ دقیقه در دمای ۱۸۰ درجه سانتیگراد سرخ کنید تا وقتی غذا ترد و کریسپی شود.</p>		۴۰۰ گرم خرچنگ مرینیت شده در اندازه‌های ۲ سانتی‌متر	چپ (A)	زمان میان‌وعده گیاهی آسیایی
		۵۰۰ گرم اسپرینگ رول گیاهی + ۴ سیخ توفوی گیاهی	راست (B)	
		۱۰۰ گرم کرکر اودانگ	پایین (C)	

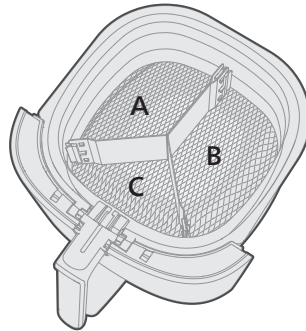

غذا	محفظه	مواد		
صبحانه	چپ (A)	۵ تخم مرغ	۱۶۰ درجه سانتیگراد	۹-۸ دقیقه
	راست (B)	۵ قطعه نان یا ۵ عدد کروسان		
	پایین (C)	۴ برش نان تست		
صبحانه انگلیسی	چپ (A)	۴ سوسیس کوچک + ۴ تکه کره صبحانه	۱۸۰ درجه سانتیگراد	۱۱-۱۰ دقیقه
	راست (B)	۴ سوفله تخم مرغ در قالب مافین		
	پایین (C)	۴ برش نان تست		
گزینه غذای ۱: ۱ سینه مرغ / سیب زمینی های کوچک / مخلوط سبزیجات	چپ (A)	۴ سینه مرغ ارگانیک کوچک	۲۲-۲۵ دقیقه، ۱۸۰ درجه سانتیگراد	اختیاری: از دماسنج استفاده کنید و روی ۷۳ درجه سانتیگراد تنظیم کنید تا بدون دردسر غذا را در یک مرحله بپزید.
	راست (B)	۹۰۰ گرم سبزیجات برش داده شده در اندازه ۱,۵ سانتیمتر مخلوط با ۱ قاشق سوپخوری روغن		
	پایین (C)	۸۰۰ گرم سیب زمینی کوچک پوست گرفته همراه با ۱ قاشق سوپخوری روغن		
گزینه غذای ۲: گوشت خوک / سیب زمینی آپیز / مخلوط سبزیجات	چپ (A)	۲ تکه گوشت خوک مرینیت شده و به ۴ قسمت مساوی تقسیم شده	۱۸۰ درجه سانتیگراد	۱. سیب زمینی ها را با پوست و به مدت ۱۲ دقیقه در دمای ۱۸۰ درجه سانتیگراد بپزید. ۲. سبزیجات را در قسمت پایین و گوشت خوک را در سمت چپ بریزید و با هم به مدت ۱۵ دقیقه در دمای ۱۸۰ درجه سانتیگراد سرخ کنید و در حین پخت، سبزیجات را یک بار هم بزنید.
	راست (B)	۴ سیب زمینی آردی در اندازه متوسط		
	پایین (C)	۸۰۰ گرم سبزیجات خرد شده در اندازه ۱,۵ سانتیمتر و مخلوط شده با ۱ قاشق سوپخوری روغن		

		المكونات	الحجرة	الأطباق
<p>١. توضع البطاطس المقلية في السلة وتُقلَى لمدة ١٥ دقيقة على ١٨٠ درجة مئوية.</p> <p>٢. يجب هز البطاطس المقلية ونقلها إلى الجهة اليمنى من السلة مع مقيّم الصينية.</p> <p>تُضاف في الجهة اليسرى ٤ قطع من السمك وتُقلَى لمدة ١٢ دقيقة على ١٨٠ درجة مئوية ويُقلب السمك في منتصف وقت الطهي.</p>	٤ قطع من السمك مع قشرة من رقائق الذرة	يسار (A)	السمك والبطاطس	
	١,٢ كجم من البطاطس المقلية المثلّجة	يمين (B)		
<p>١. يُضاف لحم البقر المشوي إلى الجهة اليسرى ويُضاف ميزان الحرارة ويُحدد البرنامج على ٦٠/٥٥/٥٠ درجة مئوية.</p> <p>٢. في منتصف وقت الطهي، تُضاف الخضار إلى الجهة السفلية والبطاطس إلى الجهة اليمنى حتى يتم بلوغ درجة الحرارة المناسبة.</p>	لحم بقر مشوي كبير بوزن ٩٠٠ غ	يسار (A)	خيار الوجبة ٣: لحم بقر مشوي مع الخضار والبطاطس	
	٨٠٠ غ من بطاطس ودجز	يمين (B)		
	٧٠٠ غ من الخضار المقطّعة	سفلية (C)		
<p>١. تُقلَى كل المكونات سوياً على ١٨٠ درجة مئوية حتى يصبح الطعام مقرمشاً.</p>	٤ ناجيت الدجاج	يسار (A)	بطاطس مقلية ووجبات خفيفة	
	٨٠٠ غ من مكعبات البطاطس	يمين (B)		
	وجبات خفيفة نباتية وفطر مع قشرة مقرمشة	سفلية (C)		
<p>١. تُضاف قطع السلطعون الصغيرة إلى الجهة اليسرى ولفائف سبرينغ رول وأسياخ التوفو إلى الجهة اليمنى، وتُقلَى لمدة ١٢ دقيقة على ١٨٠ درجة مئوية.</p> <p>٢. تُضاف المقرمشات في الجهة السفلية وتُقلَى المكونات سوياً لمدة ٤ دقائق على ١٨٠ درجة مئوية حتى يصبح الطعام مقرمشاً.</p>	٤٠٠ غ من قطع السلطعون المنقوعة بحجم ٢ سم	يسار (A)	وقت الوجبة الخفيفة الآسيوية والنباتية	
	٥٠٠ غ من لفائف سبرينغ رول النباتية + ٤ أسياخ من التوفو النباتية	يمين (B)		
	١٠٠ غ من مقرمشات اليوداغ	سفلية (C)		

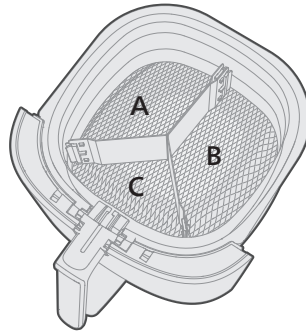

الأطباق	الحجرة	المكونات		
الفتور	يسار (A)	٥ بيضات	١٦٠ درجة مئوية	٨-٩ دقائق
	يمين (B)	٥ قطع من الخبز أو ٥ كرواسان		
	سفلية (C)	٤ شرائح من الخبز المحمص		
فتور إنكليزي	يسار (A)	٤ قطع نقانق صغيرة + ٤ قطع شحم الفتور	١٨٠ درجة مئوية	١٠-١١ دقيقة
	يمين (B)	٤ سوفليه البيض فى أكواب المافن		
	سفلية (C)	٤ قطع من الخبز المحمص		
خيار الوجبة ١: ١ صدر دجاج / بطاطس صغيرة / مزيج من الخضار	يسار (A)	٤ صدور دجاج صغيرة وعضوية	١٨٠ درجة مئوية	٢٢-٢٥ دقيقة،
	يمين (B)	٩٠٠ غ من الخضار المقطع إلى قطع بحجم ١,٥ سم مع ملعقة كبيرة من الزيت		
	سفلية (C)	٨٠٠ غ من البطاطس الصغيرة والمفشرة مع ملعقة كبيرة من الزيت		
خيار الوجبة ٢: شريحة فيليه / بطاطس مشوية / مزيج من الخضار	يسار (A)	٢ شرائح فيليه منقوعتين ومقطعتين إلى ٤ قطع متساوية	تشوى البطاطس مع قشرتها لمدة ١٢ دقيقة على ١٨٠ درجة مئوية.	١. تشوى البطاطس مع قشرتها لمدة ١٢ دقيقة على ١٨٠ درجة مئوية.
	يمين (B)	٤ بطاطس نشوية متوسطة الحجم		
	سفلية (C)	٨٠٠ غ من مزيج من الخضار المقصوصة إلى قطع بحجم ١,٥ سم مع ملعقة كبيرة من الزيت		
				٢. تُضاف الخضار في الجزء السفلي وشرائح الفيليه في الجهة اليسرى وتُقلّى سوياً لمدة ١٥ دقيقة على ١٨٠ درجة مئوية، وتُحرّك الخضار مرة واحدة أثناء الطهي.

EN Welcome, Get started! **BG** Добре дошли, да започваме! **CS** Víťáme vás v sekci Začínáme! **DA** Velkommen, kom godt i gang!
DE Willkommen! Legen Sie los! **EL** Καλωσήρθατε, ας ξεκινήσουμε! **ES** ¡Hola, empecemos! **ET** Tere tulemast, alustage! **FI** Tervetuloa, aloitetaan!
FR Bienvenue, débutez ! **HR** Dobro došli, započnite! **HU** Üdvözljük! Kezdjünk is hozzá! **ID** Selamat datang, silakan memulai!
IT Ti diamo il benvenuto. Iniziamo! **KR** 환영합니다. 지금 시작하세요! **LT** Sveiki, pradėkite naudoti! **LV** Laipni lūgti, viss gatavs lietošanai!
MK Добре дојдовте, започнете со употреба! **MS** Selamat datang, mari bermula! **NL** Welkom, aan de slag! **NO** Velkommen, kom i gang!
PL Witaj, zacznijmy! **PT** Bem-vindo, vamos começar! **RO** Bine ai venit, începe! **SK** Vitajte, začíname! **SL** Dobrodošli, začnite!
SQ Mirë se vini, fillojmë! **SR** Dobro došli, započnite! **SV** Välkommen. Nu sätter vi igång! **TH** ยินดีด้วยครับ เริ่มใช้งานเลย! **TR** Hoş geldiniz, haydi başlayalım!
UK Вітаємо, розпочнімо! **VI** Chào mừng, Bắt đầu! **SC** 欢迎您，让我们开始吧！ **TC** 歡迎，馬上開始！
AR أهلاً بك، تفضل وأبدأ الاستخدام! **IR** خوش آمدید، شروع کنید!



EN Registration and Benefits **BG** Регистрация и предимства **CS** Registrace a výhody **DA** Registrering og fordele
DE Registrierung und Vorteile **EL** Δήλωση και πλεονεκτήματα **ES** Registro y ventajas **ET** Registreerimine ja eelised
FI Rekisteröinti ja edut **FR** Enregistrement et avantages **HR** Registracija i prednosti **HU** Regisztráció és előnyök
ID Pendaftaran dan Manfaat **IT** Registrazione e vantaggi **KR** 등록 및 혜택 **LT** Registracija ir privalumai **LV** Reģistrācija un priekšrocības
MK Регистрација и поволности **MS** Pendaftaran dan Manfaat **NL** Registratie en voordelen **NO** Registrering og fordeler
PL Rejestracja i korzyści **PT** Registo e vantagens **RO** Înregistrare și beneficii **SK** Registrácia a výhody **SL** Registracija in ugodnosti
SQ Regjistrimi dhe përfitimet **SR** Registracija i prednosti **SV** Registrering och fördelar **TH** การลงทะเบียนและสิทธิประโยชน์ **TR** Kayıt ve Avantajlar
UK Реєстрація та переваги **VI** Đăng ký và lợi ích **SC** 注册和权益 **TC** 註冊與權益
AR التسجيل والمزايا **IR** ثبتنام و فواید آن



EN Digital manual **BG** Дигитално ръководство **CS** Digitální příručka **DA** Digital manual **DE** Digitales Handbuch **EL** Ψηφιακό εγχειρίδιο
ES Manual digital **ET** Digitaalne kasutusjuhend **FI** Digitaalinen käyttöopas **FR** Manuel numérique
HR Digitalni priručnik **HU** Digitális kézikönyv **ID** Manual digital **IT** Manuale digitale **KR** 디지털 설명서 **LT** Skaitmeninis vadovas
LV Digitālā rokasgrāmata **MK** Дигитално упатство **MS** Manual digital **NL** Digitale handleiding **NO** Digital håndbok
PL Elektroniczna instrukcja obsługi **PT** Manual digital **RO** Manual digital **SK** Digitálna príručka **SL** Digitalni priručnik **SQ** Manuali digjital
SR Digitalno uputstvo **SV** Digital användarhandbok **TH** คู่มือดิจิทัล **TR** Dijital kılavuz **UK** Цифровий посібник **VI** Hướng dẫn kỹ thuật số
SC 数字手册 **TC** 數位手冊
AR الدليل الرقمي **IR** راهنمای دیجیتال



PHILIPS and the Philips Shield Emblem are registered trademarks of Koninklijke Philips N.V. and are used under license.

This product has been manufactured by and is sold under the responsibility of Versuni Holding B.V., and Versuni Holding B.V. is the warrantor in relation to this product.

2024 © Versuni Holding B.V.

04/06/2024